

# ASSEMBLY INSTRUCTIONS

## SMAWRDFSC - Floorstanding Rotating Display

PARTS LIST:	Qty.
A. Wooden Panel - Top	1
B. Wooden Pole	4
C. Acrylic Shelf - Large	14
D. Acrylic Shelf - Small	14
E. Wooden Panel - Bottom	1
F. Rotating Plate (mounted on G)	1
G. Wooden Base	1

HARDWARE:	
H. M6 Screw	16
I. M4 Screw - Short	56
J. M4 Screw - Long	3

Please read these instructions carefully before assembling the product.

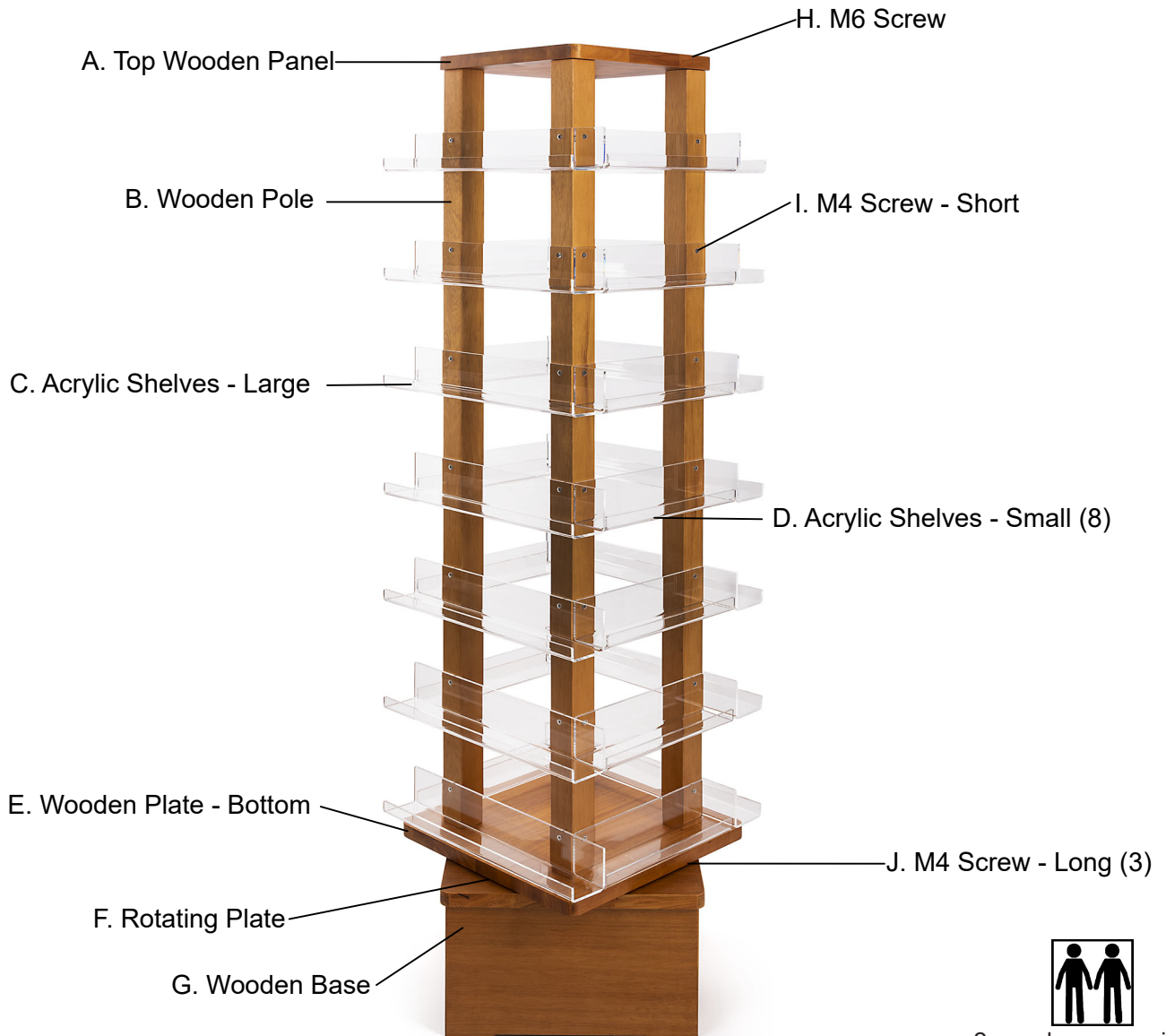

2 people are required

If you have any questions regarding our products, please visit us at [www.displays2go.com](http://www.displays2go.com)  
or contact D2G customer service 844-221-3388.

# ASSEMBLY INSTRUCTIONS

## SMAWRDFSC - Floorstanding Rotating Display

**STEP 1.** Place the Top Wooden Panel (A) on top of 1 Wooden Pole (B) and align the holes on the pole with the pre-drilled holes at 1 corner of the panel. Insert 2 M6 Screws (H) through holes on the panel and tighten them to connect the pole. Repeat the step to connect the remaining poles with the top panel.

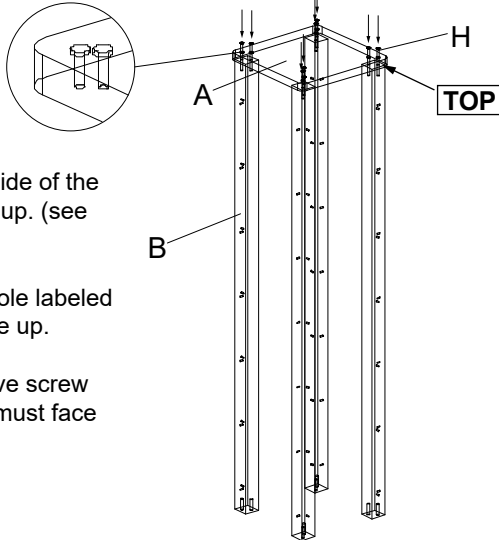

**NOTE:**

- a. The countersink side of the top panel must face up. (see detailed view)
- b. One end of the pole labeled with "TOP" must face up.
- c. The sides that have screw holes on each pole must face outside.

**STEP 2.** Hold the poles and the top panel, and carefully turn the assembled frame upside down. Attach Bottom Wooden Panel (E) to the open end of the poles and secure it using 8 M6 Screws (H).

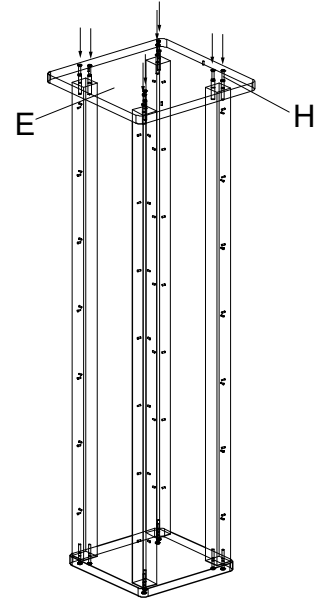

**NOTE:**

- a. The countersink side of the bottom panel must face up.
- b. Keep the assembled frame in current position until STEP 4 is finished.

**STEP 3.** Place the Wooden Base (G) on the floor upside down.

Rotate the base to align the through hole on the wooden base with 1 hole on the Rotating plate (F). Insert 1 M4 Screw - Long (J) through the hole and let it rest on the rotating plate.

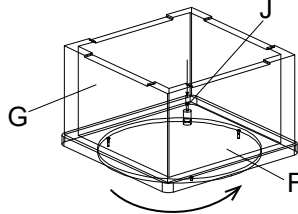

**STEP 4.** Lift the base up and place it onto the assembled frame. Align the inserted M4 screw on the round plate with 1 screw hole on the bottom panel and screw it into the bottom panel.

**NOTE: DO NOT TIGHTEN THE SCREW! DOING SO MAY BREAK THE ROTATING PLATE!**

Rotate the wooden base and align remaining holes on the rotating plate with the corresponding screw holes. Insert 1 M4 screw (long) at a time and screw it into the hole without tightening.

NOTE: Maintain an even amount of force across 3 screws when fastening.

**DO NOT OVER-TIGHTEN SCREWS!  
DO NOT USE POWER TOOL!**

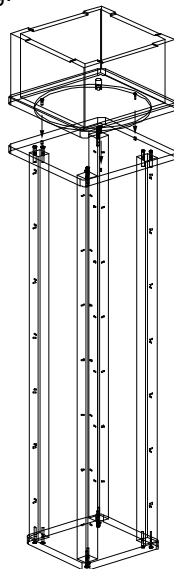

**STEP 5.** Carefully place the assembled unit on its standing position. Assemble Small Shelves (D) and Large Shelves (C) onto the display body with M4 screws - Short (I).

**NOTE:** DO NOT assemble the same sized acrylic shelves on adjacent sides of the display.

