



# Collaborate Series All In + One 163" Wall Mount

## Operation Manual

---

Please read the safety information carefully before using this product.  
After reading this manual, keep it in an easily accessible location for future reference.

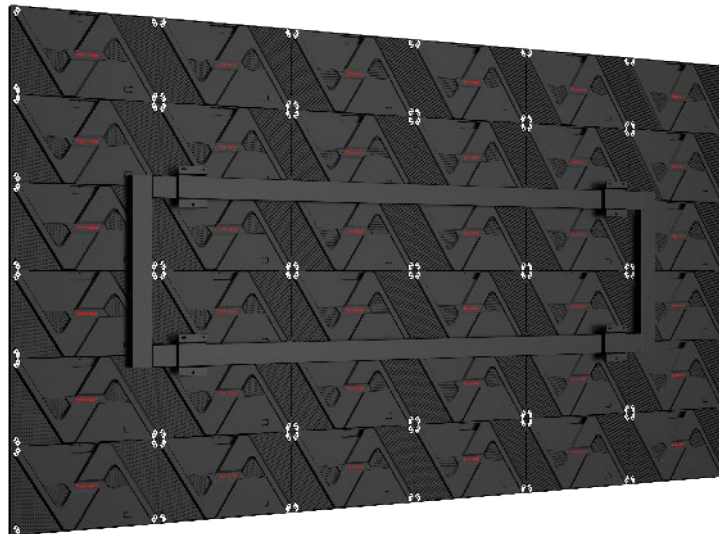



# TABLE OF CONTENTS

SAFETY PRECAUTIONS .....4

## GUIDELINES

--Maintenance Guidelines.....5

## SPECIFICATIONS

--Technical Specifications.....6  
--Panel Overview.....7  
--Parts Overview.....8

## TOOLS REQUIRED

--Tools Needed for Installation and Maintenance .....9

## INSTALLATION

--Confirm Installation Position.....10  
--Mark Holes.....10  
--Drill Holes.....11  
--Install Corner Plates.....12  
--Check and Connect Mounting Bracket .....12  
--Install Mounting Bracket.....13  
--Secure with Screws.....13  
--Install Corner Plates.....14  
--Review of Panel Display Sticker and Hanging Panel Order...14  
--Hanging the Panels.....14  
--Check Panel Order.....17  
--Panel Connections: Alignment Brackets & Captive Screws...18  
--Optional Touch Screen Installation.....19  
--Installing the Trim.....19  
--Connect Main Power.....22  
--Connecting Power Jumpers.....23  
--Connect Main Data.....25  
--Connecting Data Jumpers.....25  
--Connect the Processor Housing.....26  
--Connect the TU20 LED Processor.....27  
--Starting the Collaborate Screen.....27  
--Installation the Modules into the Panels in Order.....28

## MAINTENANCE

--Module Maintenance .....31  
--Replacing the Power Supply.....32  
--Hub Card Maintenance.....33

WARRANTY .....34

**WARNING** - This equipment is compliant with Class A of CISPR 32. In a residential environment this equipment may cause radio interference.

## **SAFETY PRECAUTIONS**

The safety precautions are intended to prevent unexpected danger or harm by helping the user to use the product safely and for its intended purpose.



### **WARNING**

If you ignore the warning message, you may be seriously injured or there is a possibility of accident or death.



### **CAUTION**

If you ignore the caution message, you may be slightly injured or the product may be damaged.



### **WARNING**

Indoor Use Only.

### **PLEASE NOTE:**

Direct view LED modules are extremely fragile. Please make sure the members of your installation team understand that, from unpacking to installation, care must be taken to avoid damage. Pixel outages on new modules do happen and, in most cases, may be sent to ATS-Pro for warranty repair, for a period of two years. However, multiple missing pixels, and edge or corner damage is typically the result of mishandling and may incur a repair fee or render a module unrepairable.

# MAINTENANCE GUIDELINES

Careful and regular maintenance is necessary to optimize the potential functional lifespan of the LED video panels.

## 1. READ INSTRUCTIONS

Familiarize yourself with the installation and operation instructions to ensure correct usage of the LED video panels.

## 2. AVOID IMPACT DAMAGE

Although the panels are designed to withstand some impact forces, handle and transport them carefully, especially at corners and edges, which are particularly vulnerable.

## 3. CHECK FASTENERS

Regularly inspect each LED video panel for loose screws and other fasteners.

## 4. INSPECT INSTALLATION EQUIPMENT

For fixed installations displayed for extended periods, routinely check all connecting plates and installation equipment. Replace or repair as necessary. During long periods of non-use, disconnect the main power.

## 5. USE ESD PRECAUTIONS

Employ necessary electrostatic discharge (ESD) precautions when handling the LED video panels, especially the screens, as they are sensitive and can be easily damaged.

## 6. GFI BREAKER CHECK

If the Ground Fault Interrupt (GFI) breaker-switch trips frequently, inspect the display or replace the power supply switch.

## 7. POWER SEQUENCE

Power on the the LED video panels before powering the processor.

## 8. TROUBLESHOOTING

If any electrical abnormalities occur during testing (e.g., circuit shorts, tripped breakers, burnt wires), discontinue testing and troubleshoot the units to identify the problem before resuming operation.

## 9. LEARN OPERATING PARAMETERS

Understand the operating parameters for installation, data recovery, backup, processor settings, and basic data preset modifications to ensure consistent operation.

## 10. STORAGE

When not in use, store the LED video panels in a dry, well-ventilated facility.

By following these guidelines, you can help ensure the longevity and optimal performance of your LED video panels.

# TECHNICAL SPECIFICATIONS

## Specifications

## Collaborate 163

LED Type	Flip Chip COB
Pixel Pitch (mm)	1.87
Screen Dimensions (W*H)/(mm)	3600 x 2025
Screen Dimensions (W*H)/(ft)	11.81 x 6.64
Screen Resolution (dots)	1920 x 1080
Brightness (nit)	600
Refresh Rate (Hz)	3840
Gray Scale (bit)	13 Bit
Contrast Ratio	15,000:1
Viewing Angle	160/160
Power Consumption (Max./Avg.) (W/m <sup>2</sup> )	325/108
Operating Voltage	110v ~ 240v

## NovaStar TU20 Processor

Touch Option	± 1mm touch accuracy, 20 simultaneous touch points
Android System	Android 11.0
Mirror From	Windows, macOS, iOS, and Android
Handheld Remote	Included
Processor Core	Main Frequency 1.8G 64-bit Quad-core Processor
Storage	4GB + 32GB
Control Interface	1 × RJ45; 1 × RS232
TU20-Pro Input/Output Interface	(2) HDMI 1.3 IN, (3) USB 2.0 IN, (1) Audio OUT, (1) SPDIF OUT
Mounting Options	Stand or Wall Mount
IP Rating (Front/Rear)	IP40/IP21

Specifications subject to change. Please contact ATS-Pro for updated specifications.

# PANEL OVERVIEW



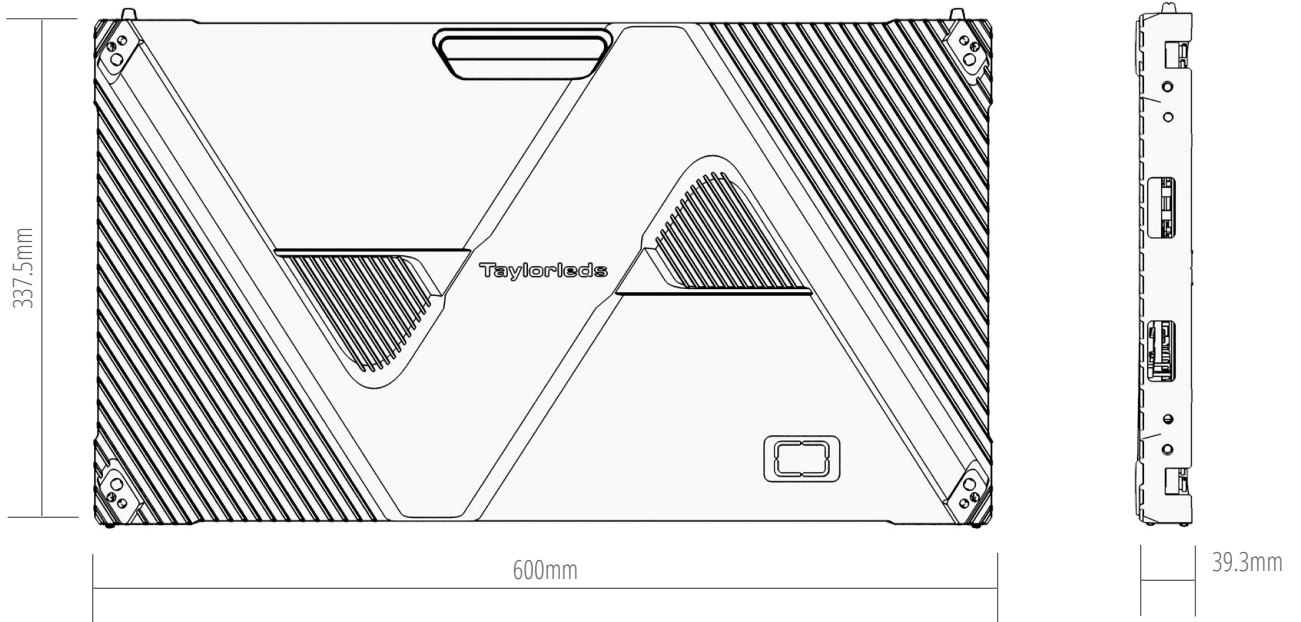



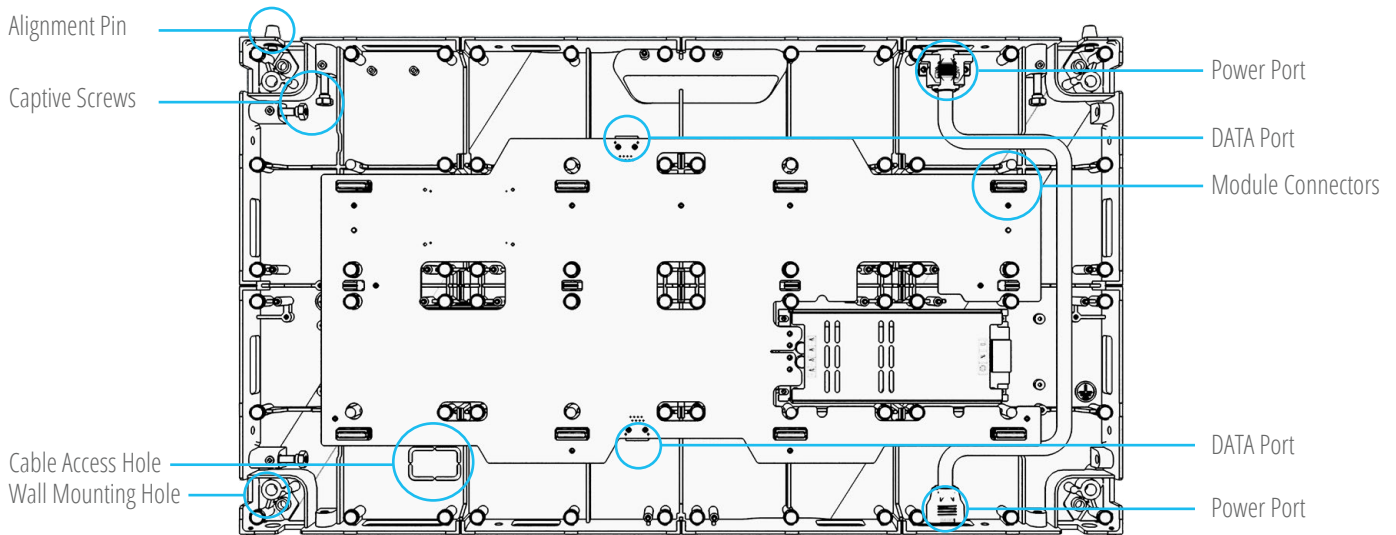



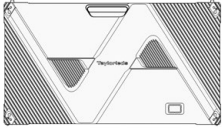
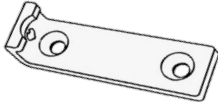
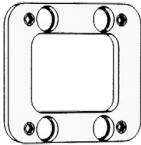

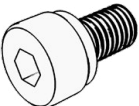



## Rear View



## Front View

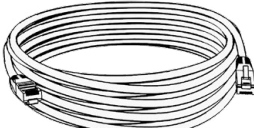

# PARTS OVERVIEW

PART		QTY	PART		QTY
Cabinets 600 x 337.5mm		36	Lift Hooks: 30 x 80 x 21.25mm		20
Inside Alignment Bracket: 80 x 71 x 10mm		25	Screws (Lift Hooks) M6 x 16		40
Screws (Inside Alignment Bracket) M8 x 12		100	Left Trim: 1697.5mm Right Trim: 1697.5mm		1 ea
Mounting Brackets 4 top, 2 Sides		6	Top Trim B: 1800mm Bottom Trim B: 1800mm		2 ea
Mounting Brackets Linking Pins		4	Trim Connection: Screws & Nuts:		24 ea
Mounting Brackets Linking Pin Screws		10	Main Power Cable (M)		3
Corner Connecting Pieces A 120x168mm		4	Power Jumper Cable (F-F)		2
Corner Connecting Pieces B 180x168mm		2	Main Data Cable		5
Safety Screws (Corner Connecting Pieces): M6 x20		20	Data Jumpers		12
Screws (Beam Connection): M8 x 60		8			

**\*NOTE:** Several bags of spare parts that are not listed here will be included for your convenience.

# TOOLS REQUIRED

## Installation Tools Included

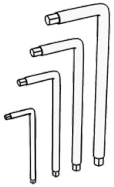

3mm, 5mm, 6mm,  
Allen Wrenches

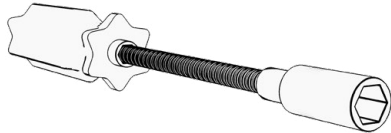

Hexagon Socket Driver



Adjustable Wrench

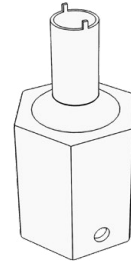

Magnet Adjustment Tool

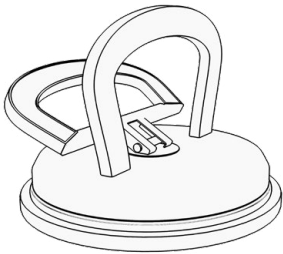

Module Service Tool

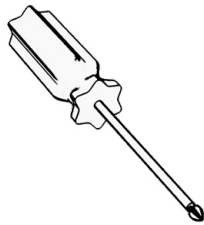

Phillips Head Screwdriver

**\*NOTE:** Additional tools for installation are required: flathead screw driver and additional metric allen wrenches.

## Additional Items Included

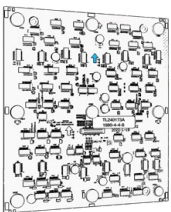

Replacement Modules

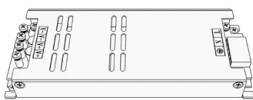

Spare Power Supply



Spare HUB Board



USB Software /  
Document Drive

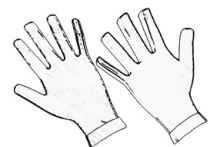

Gloves

# INSTALLING A TAYLORLEDS COLLABORATE 163" WALL MOUNT VERSION

## Step 1: Confirm Installation Position

Use the diagram below to correctly place the Collaborate screen on the wall.

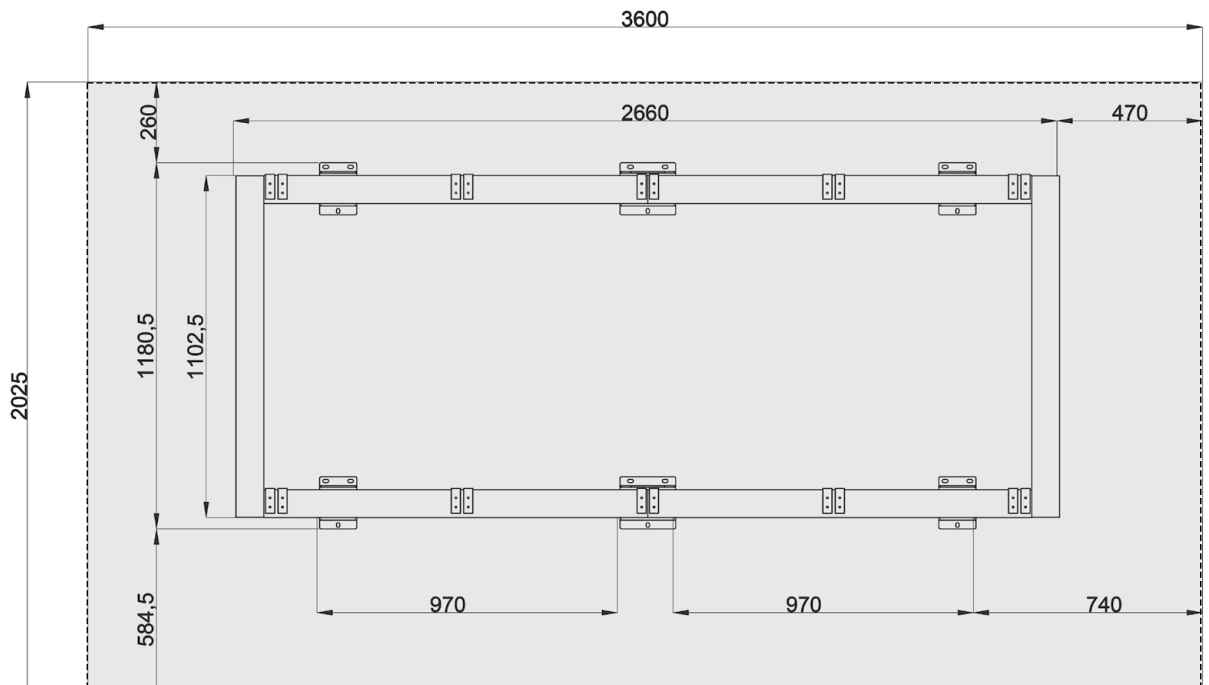

**Note:** Vertical height of bracket mount isn't perfectly center.

## Step 2: Mark Holes

Mark drilling holes for corner plates on the wall

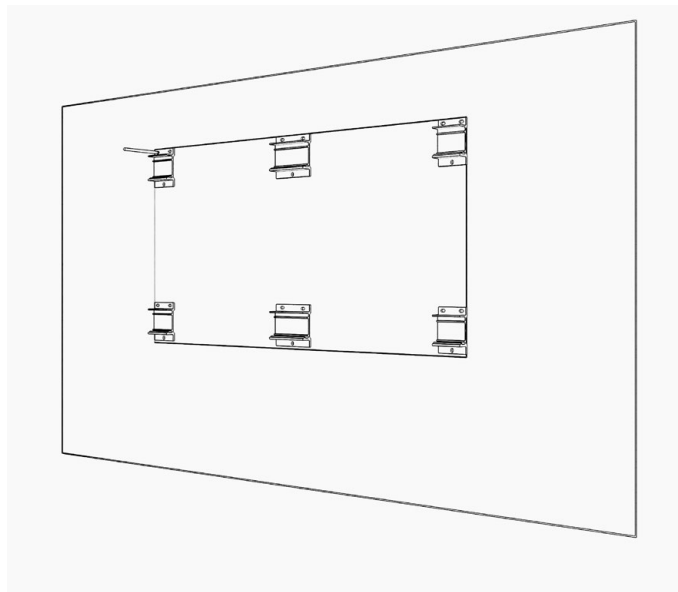

### Step 3: Drill Holes

Use a drill to screw the expansion screws into the wall.

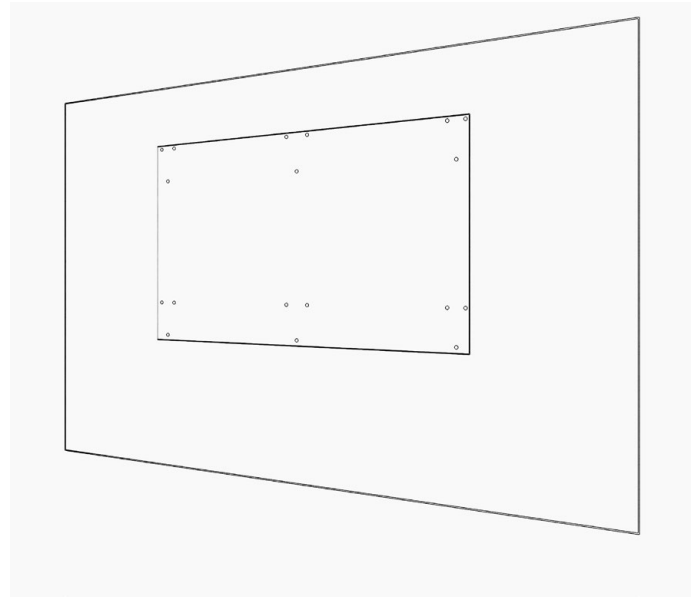
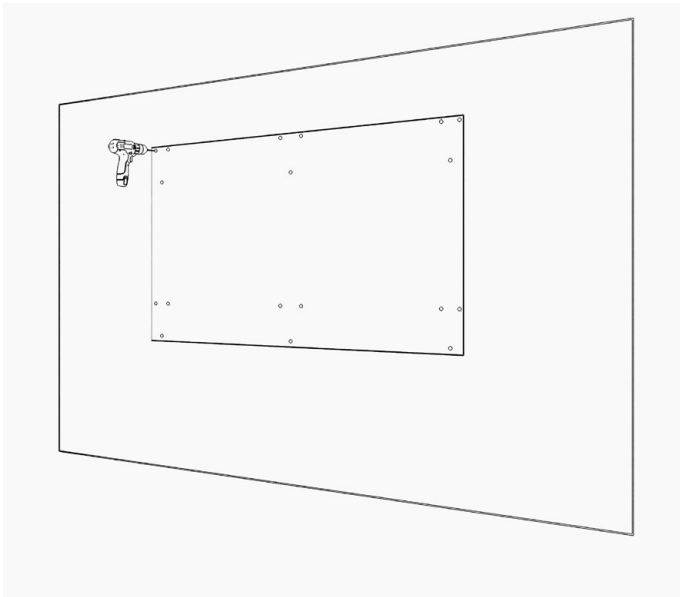

### Step 4: Install Corner Plates

Tighten bolts to secure the corner connecting plates.

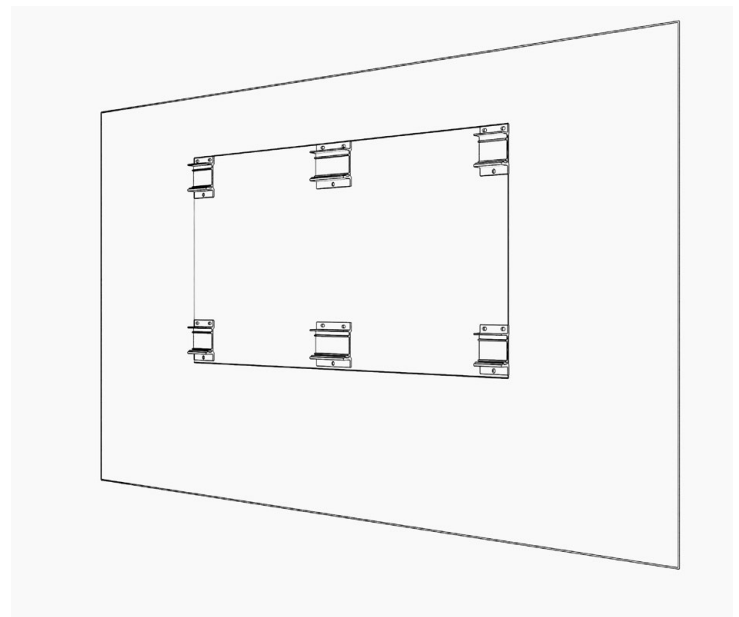
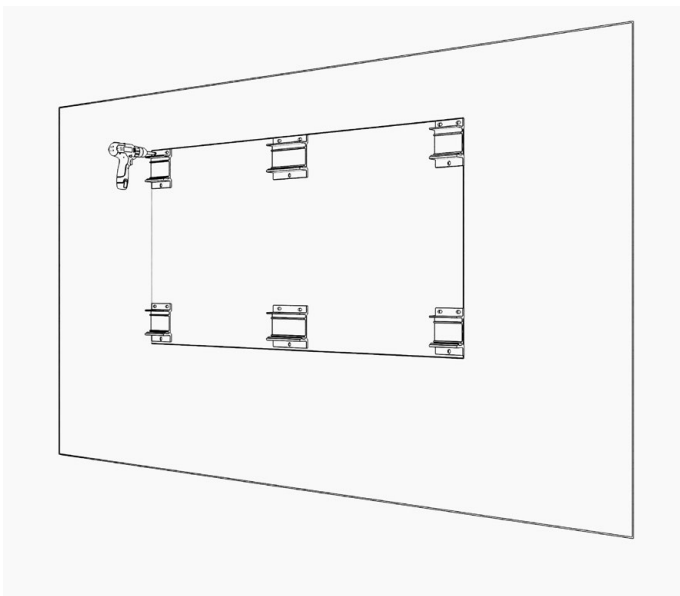

## Step 5: Check and Connect Mounting Brackets

Ensure the side with the arrow on the horizontal beam is facing forward and upwards. Use M8x60 screws to connect all four sides.

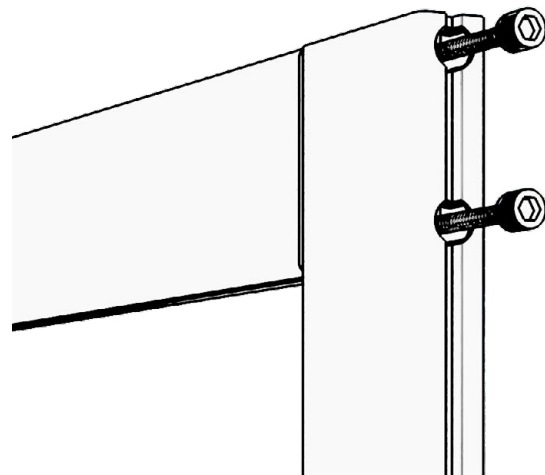
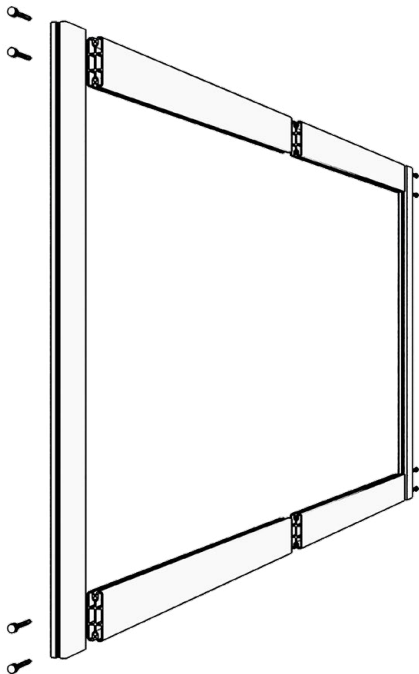
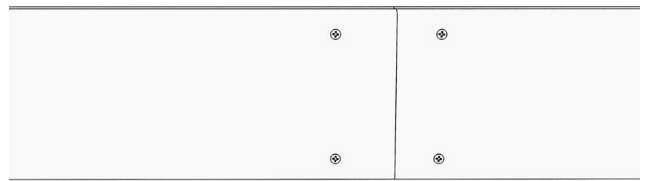
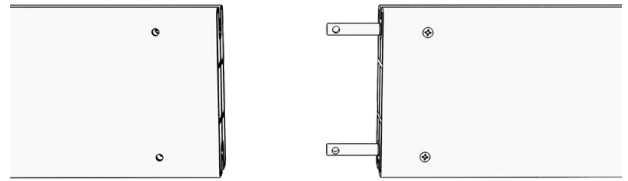
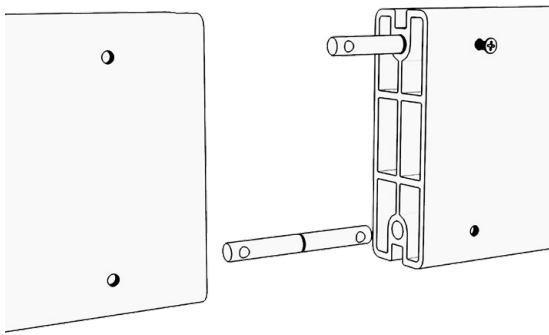
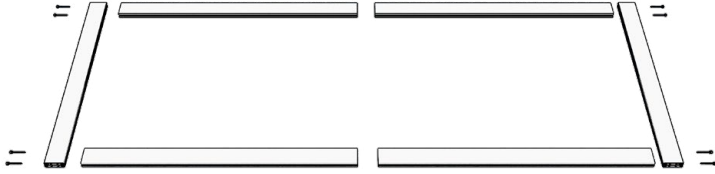

### Step 6: Install Mounting Bracket

Check the arrow mark and attach to corner connecting plates.

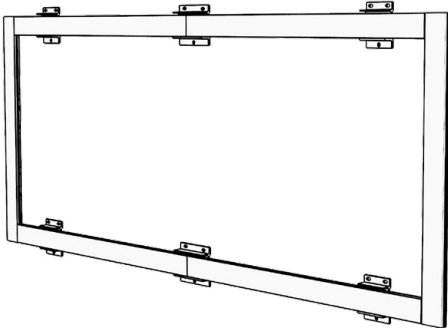
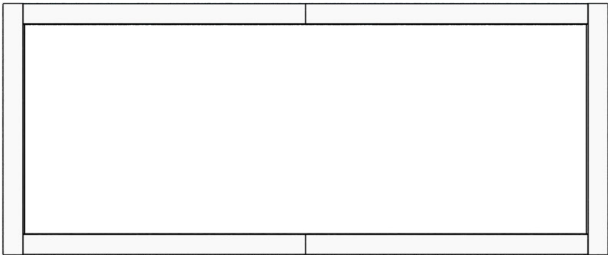

### Step 7: Secure with Screws

Use M6x20 screws to fix the mounting bracket to the plates.

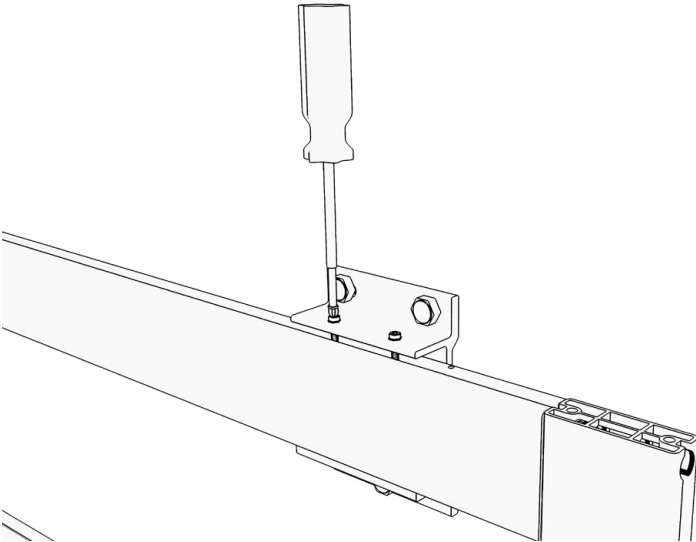

## Step 8: Review of Panel Display Sticker and Hanging Panel Order

**PARTS NEEDED:** WN Series LED Panels

**Very Important:** The panels must go into the designated position on the Collaborative wall. The label below indicates this position, and the panel number on the label corresponds to this position.

### Display Installation Sticker:

Panel numbers are marked on a sticker inside the panel. This indicates panel position in the wall; for example, 1-1, 1-2, 1-3 means the first panel in the first row of the screen, the second panel in the first row, and the third panel in the first row.

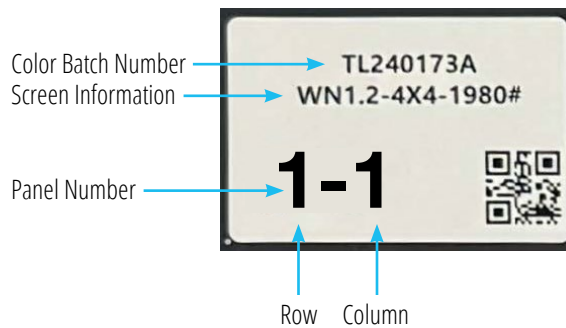

There is a second sticker inside the module that illustrates an example of panel installation order.

Display Installation			Module Installation Take			
1-1	1-2	1-3	1-1 for example			
2-1	2-2	2-3	1-1-1	1-1-2	1-1-3	1-1-4
3-1	3-2	3-3	1-1-5	1-1-6	1-1-7	1-1-8

The illustration below shows an example of the top 2 rows of a 163".

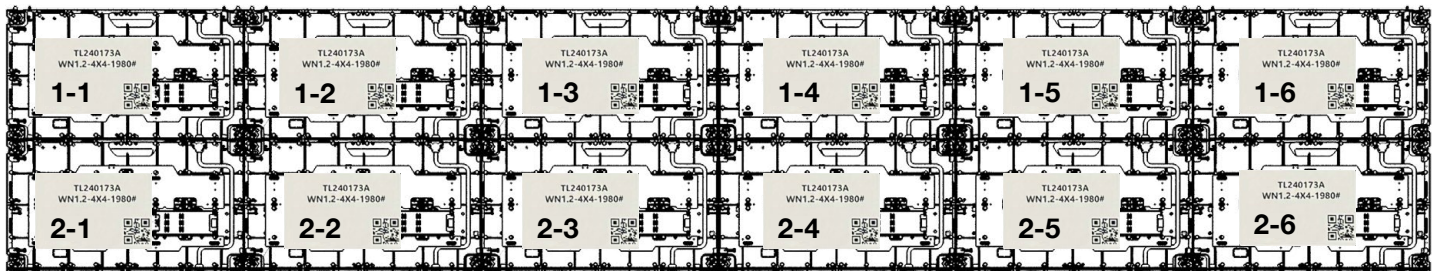

## Step 9: Hanging the Panels

**TOOLS NEEDED:** 4mm Allen Wrench

**PARTS NEEDED:** (20) Lift Hooks  
 (40) Lift Hook Screws: M6 x 16

**Start from the center column of screens.**

When assembling the Collaborate wall, work from the center point of the cross beam. For this size, find panel 5-4 and 6-4. These are the lower-middle panels. Arrows on the inside of the panel point to the top. Secure the two panels with the two captive screws located at the top of the panel. Hand-tighten the captive screws.

**PRO TIP:** Line up all of your boxes in order by number ahead of time to speed up the installation process.

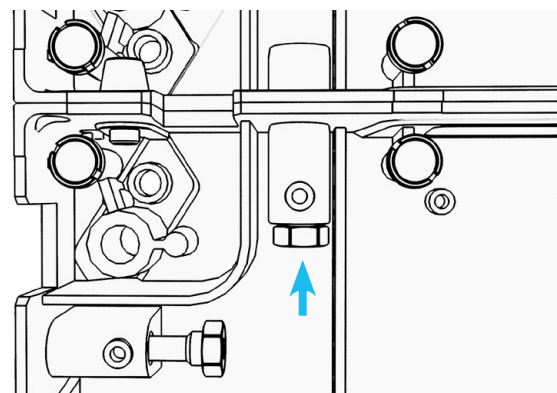
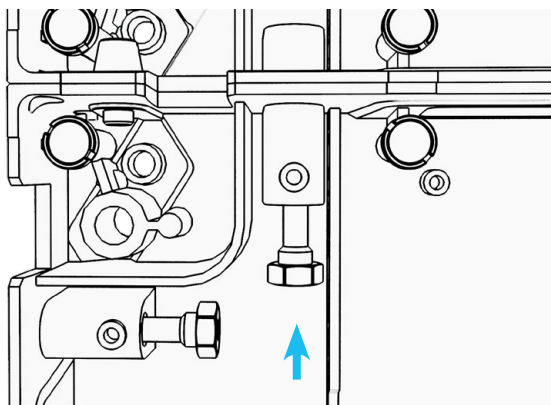

When you attach the panels together, the alignment pins will help guide them into place.

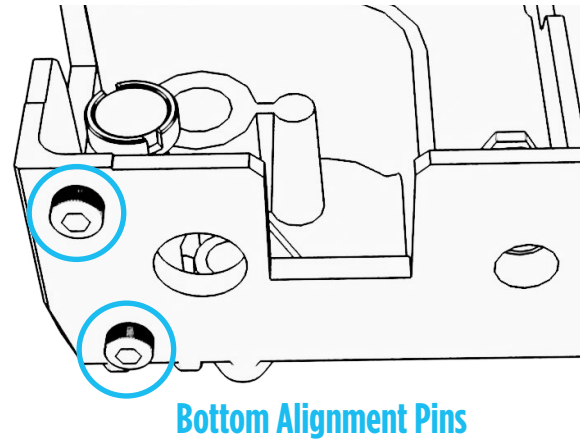
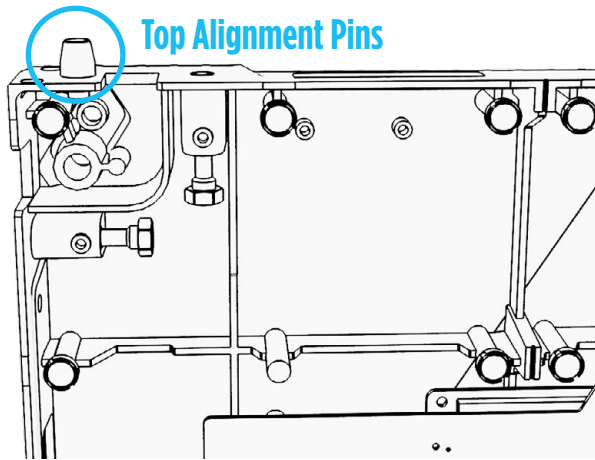

Start with the middle column of panels (1-3 through 5-3). Flip panels 1-3 and 2-3 over. Take two lift hooks and screw them to the back of the LED panels, one on the left and one on the right. This will connect the two panels. Do the same for panels 4-3 and 5-3 as shown below. You will only need to place lift hooks according to the diagram below. Connect both sets with panel 3-3 so you have one column.

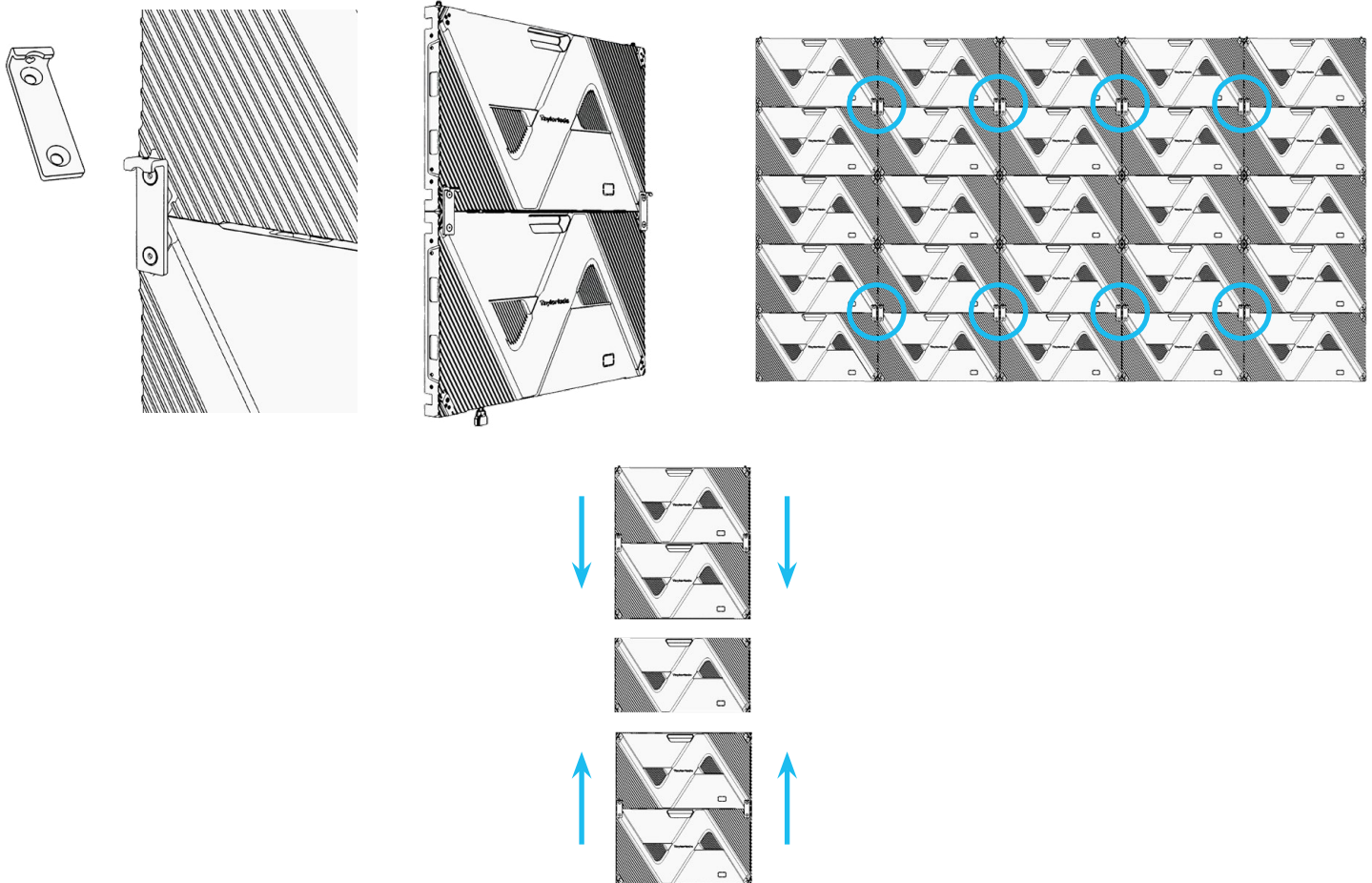

Connect the column together using alignment pins to guide panels into place. Hand tighten the horizontal captive screws.

Carefully lift the column of connected panels and hang them onto the beam, ensuring the hooks fully engage into place. The front of the panel will be on the side of the legs with the **L** and **R** stickers. Make sure this middle column of the panels is centered on the beam. For reference, the horizontal beams are 2240mm long. Measure 1120mm from one side to find the center. Each panel is 300mm wide. Measure 150mm from the center and align one of the edges to that measurement.

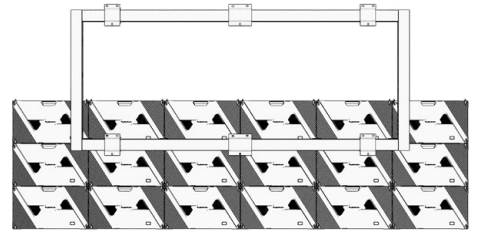
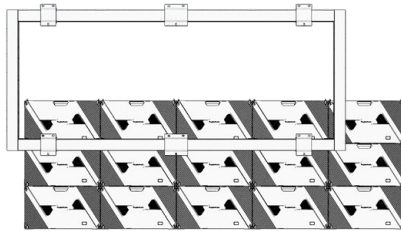
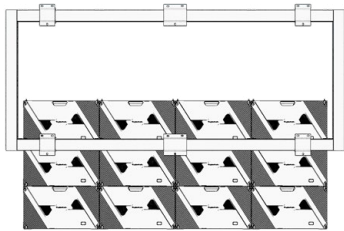
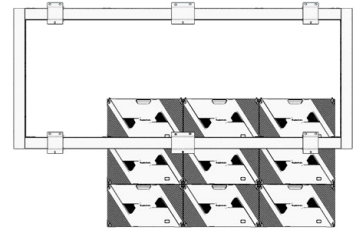
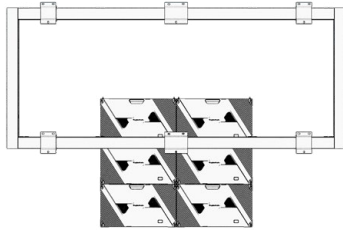
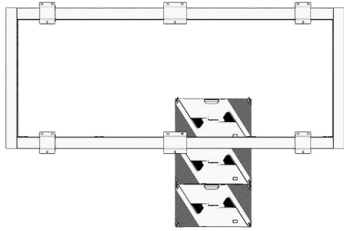

**NOTE:** When you start on the panels that hang on the sides, only put one **Lift Hook** on the inside of the panel as shown in the diagram on the previous page.

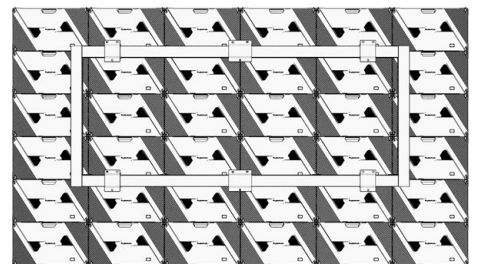
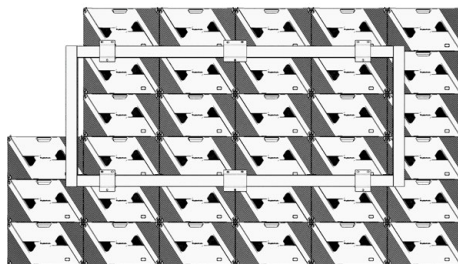
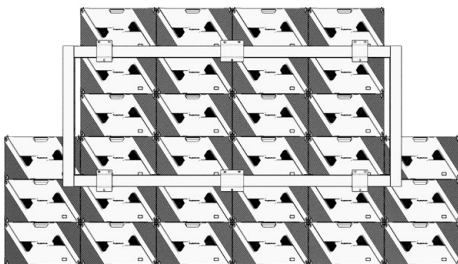
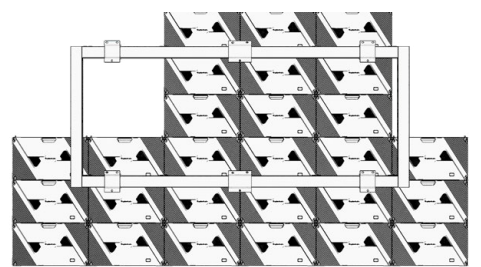
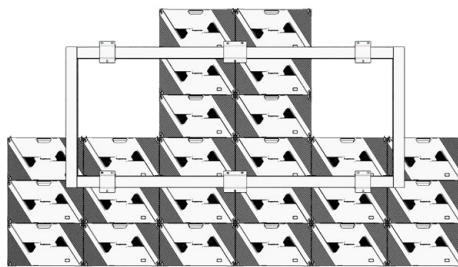
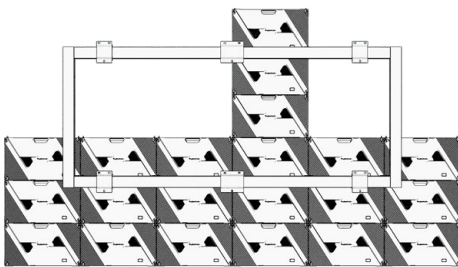

## Step 10: Check Panel Order

**VERY IMPORTANT:** Before proceeding to the next step, check the display installation sticker on each panel to ensure the panel numbers are in the proper order. After installing all the panels, confirm that all lift hooks are securely on the beam. Ensure panels are level and hand tighten all the captive screws on the sides, and top of each panel.

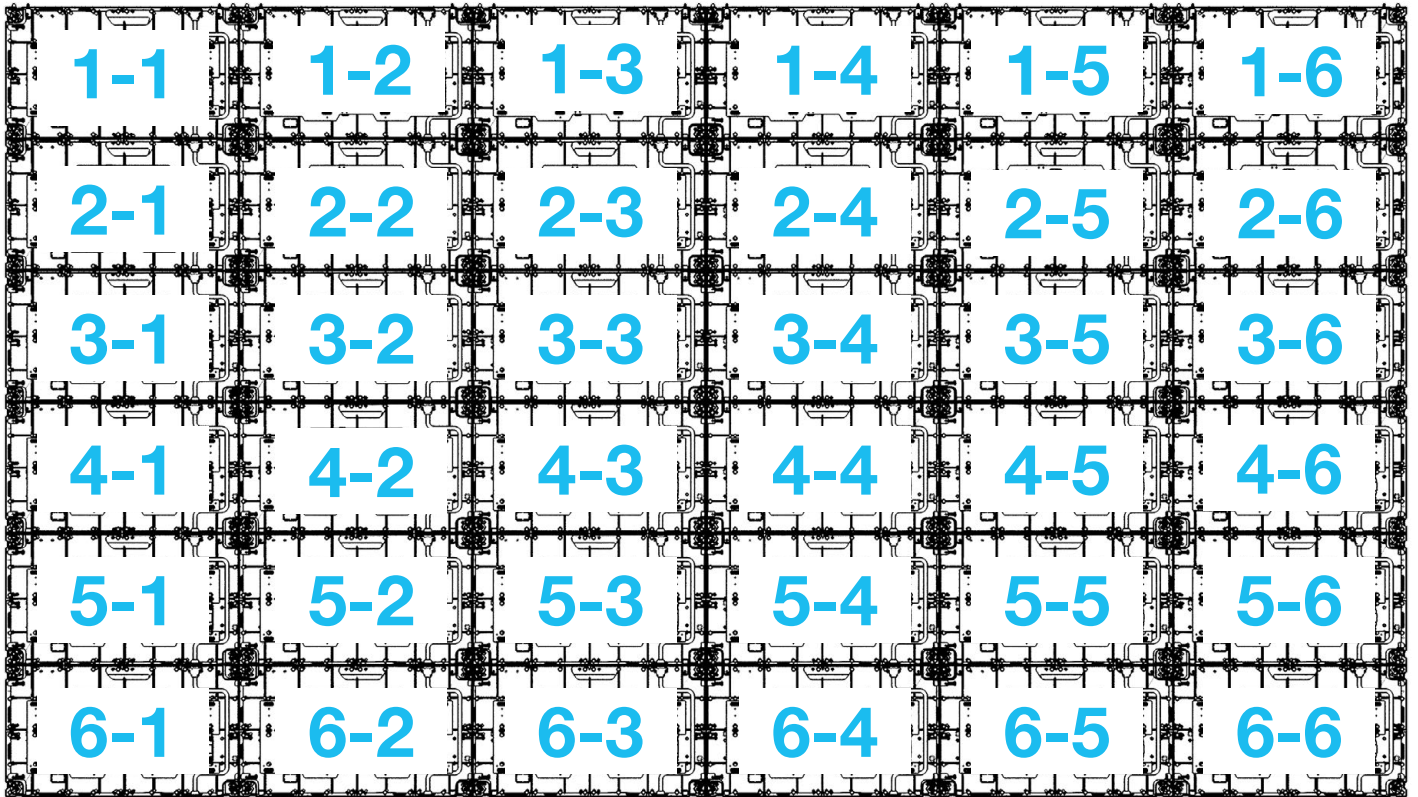
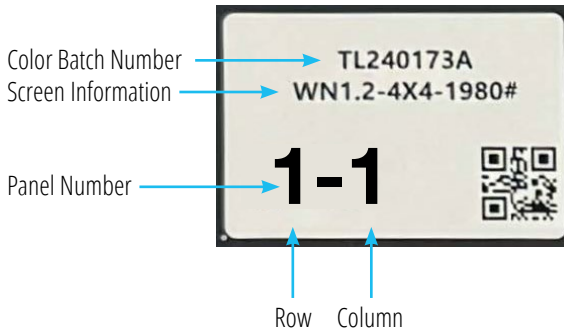

## Step 11: Panel Connections: Alignment Bracket and Captive Screws

TOOLS NEEDED: 6mm Allen Wrench  
PARTS NEEDED: (25) Alignment Brackets  
(100) Screws M8 x 12

### Install the Internal Alignment Brackets

The alignment brackets help with the alignment of the panels. Install one bracket at every quad corner. Once all screws are in place, tighten with 6mm allen wrench.

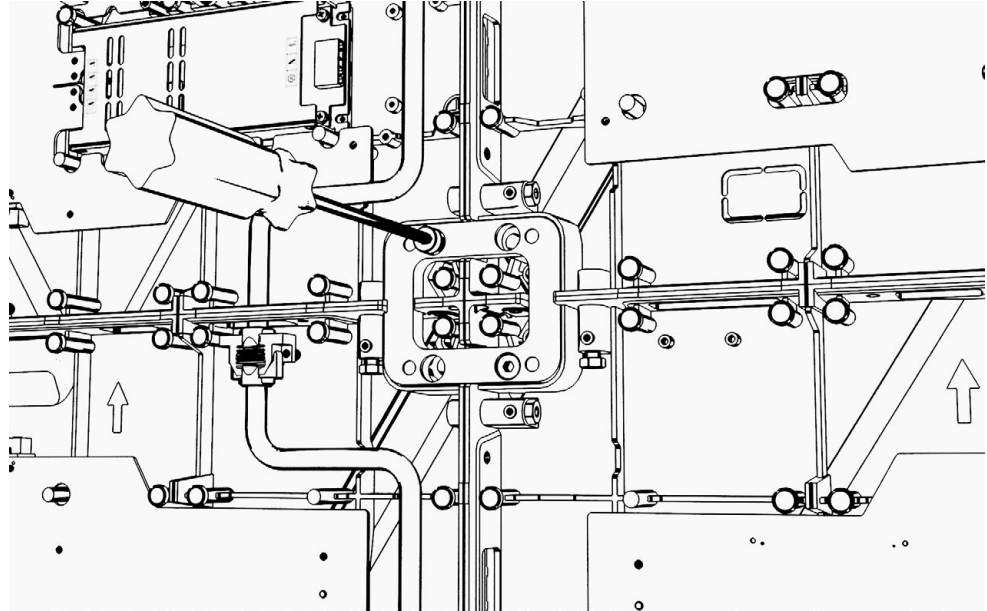
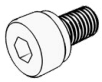
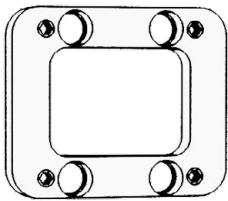

### Tighten All Captive Screws

Ensure panels are level, then ensure all screws are snug.

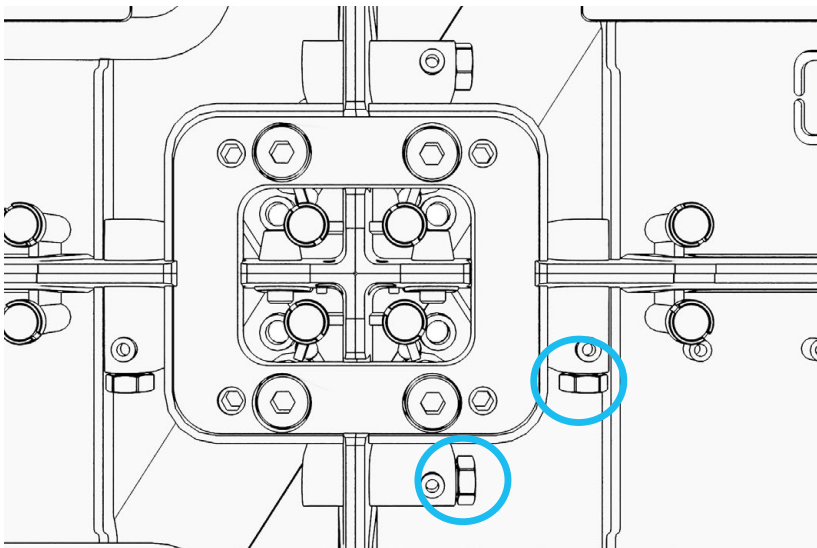

Captive Screws

## Step 12: Optional Touch Screen Installation

If you have a touch screen, please refer to the touch screen manual before proceeding to the next step.

## Step 13: Installing the Trim

**TOOLS NEEDED:** 2.5mm Allen Wrench  
Wrench  
Flat Head Screw Driver (very thin)  
Small Phillips Head Screw Driver  
Hexagon Socket Driver

**PARTS NEEDED:** Trim (6)  
Trim Screws M5 x 35 (24)  
Nuts (24)

Before installing the trim, follow these steps to ensure the top and sides are flush and flat:

### 1. Remove Alignment Pins

Begin by removing the alignment pins located on the top panel using a screwdriver.

### 2. Remove Captive Screws

Next, remove all the captive screws from both the top and side panels. To do this, unscrew the smaller screws that hold them in place.

### 3. Remove Top Power Connector Screws

Remove the philips heads screws that hold the Power Out cable on the top panels. This will prepare the panels for the trim installation by ensuring a smooth surface.

### 4. Remove Corner Alignment Pin Screws

Remove the screws on the corner of all the bottom panels with an Allen wrench.

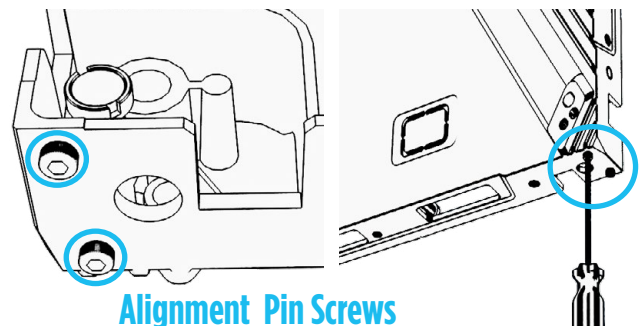
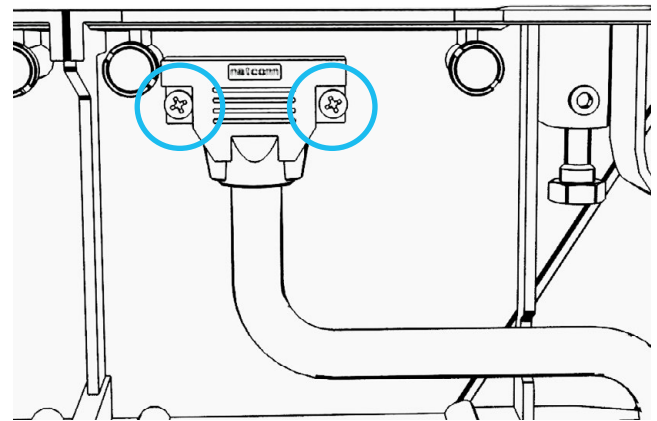
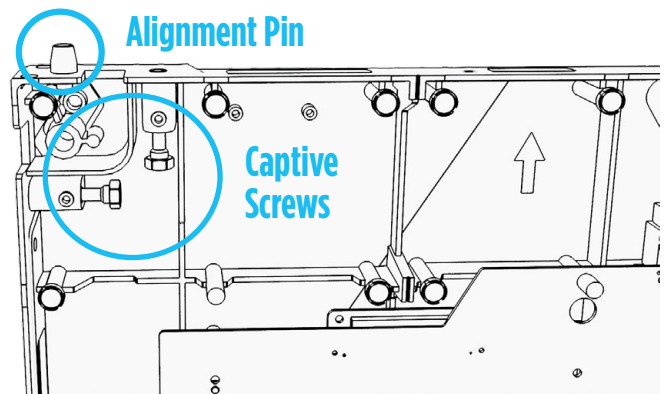

## 5. Prepare the Trim for Installation:

1. Screw two trim bolts into each piece of trim with a 2.5mm Allen wrench.

**Note:** As shown in the photo, the left side of the trim is shorter than the right. When installing, ensure the short side faces the **front** of the LED wall for proper alignment.

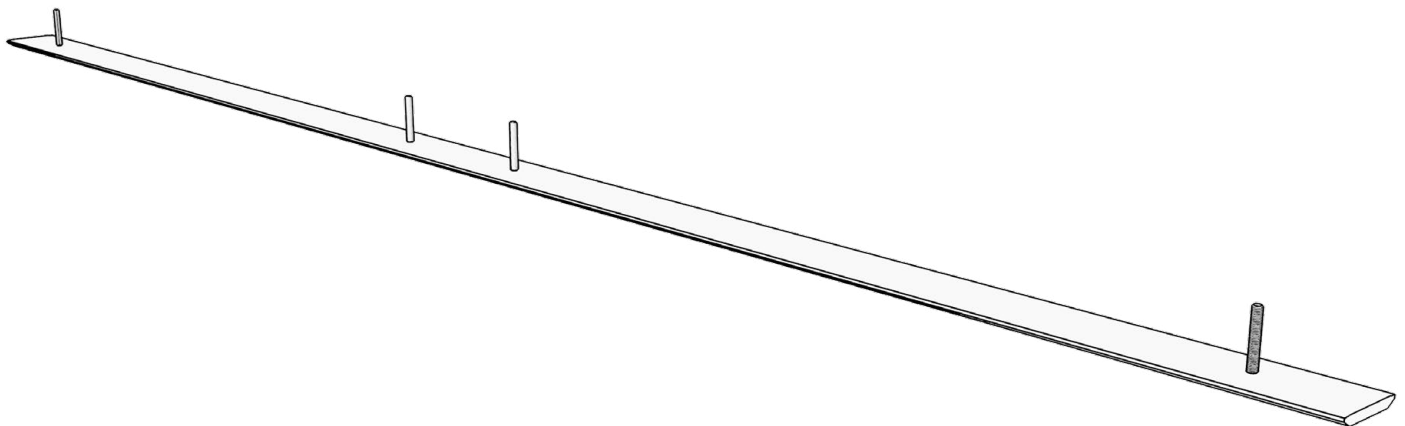
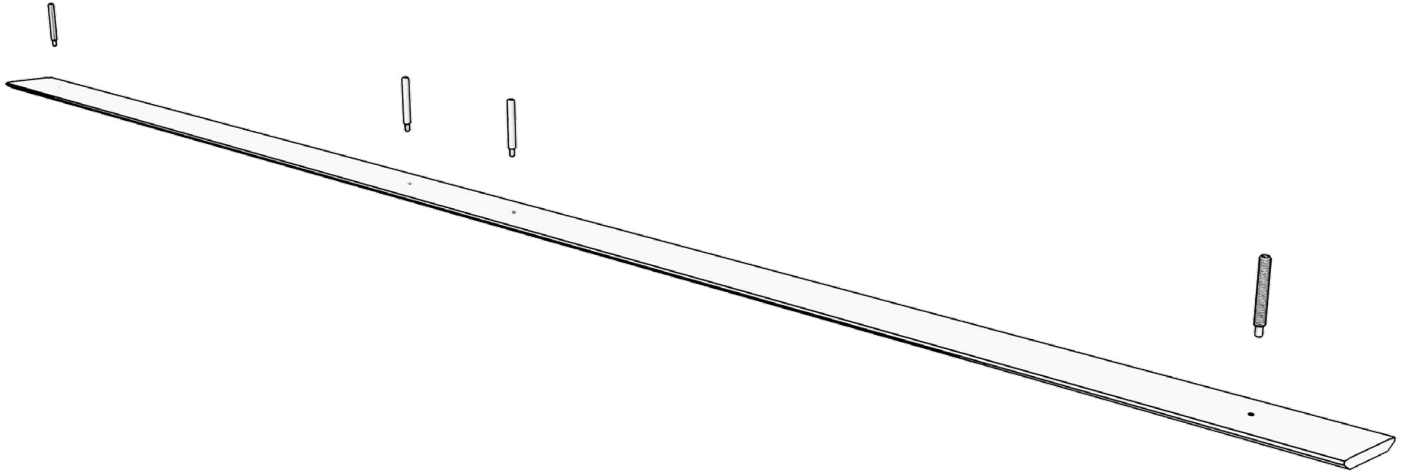
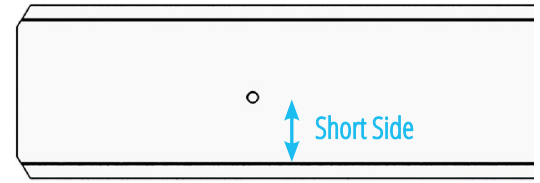

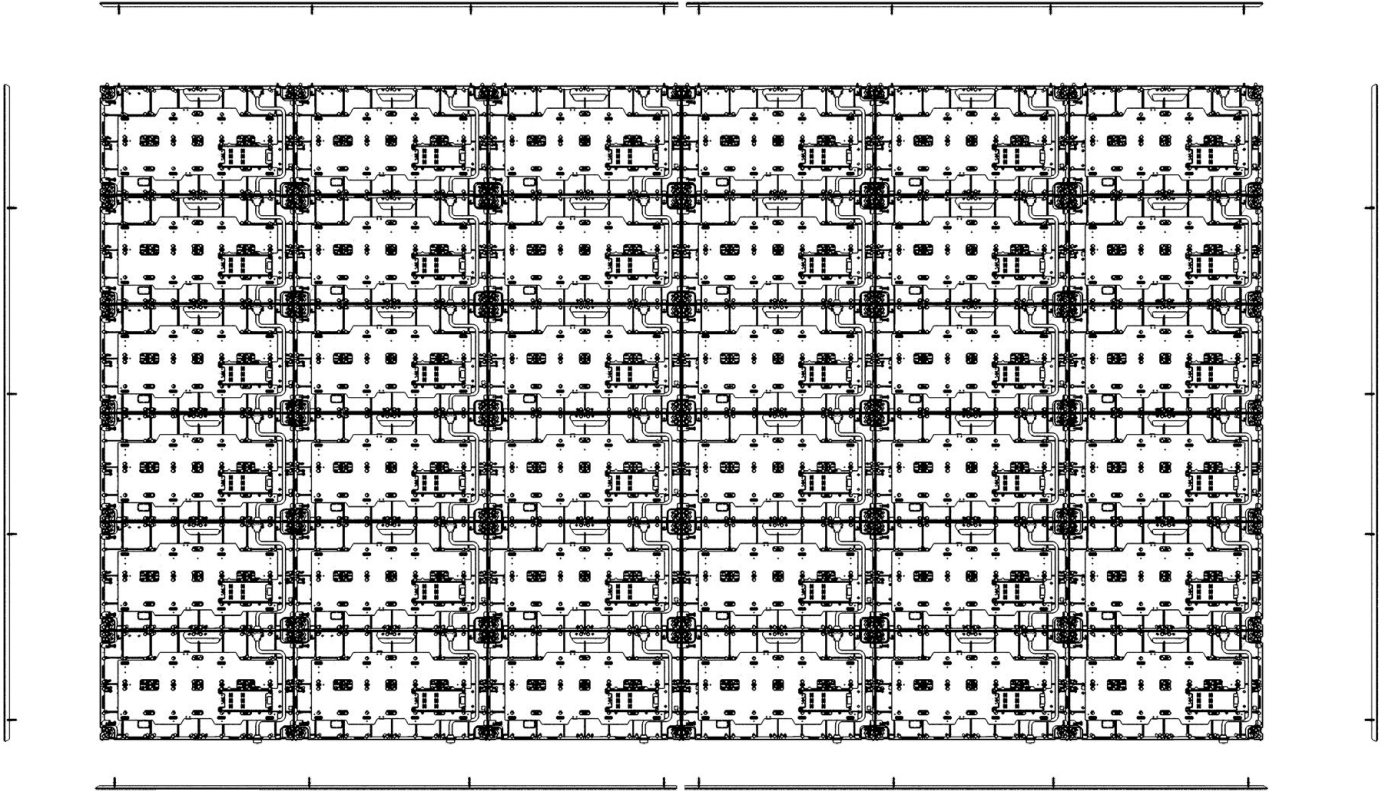

## 6. Install the Trim Pieces:

1. Insert the trim bolts into the holes left by the captive screws on the LED panels.
2. Secure the trim by fastening the nuts to the bolts.
3. Repeat this process for all four sides of the panel to ensure the trim is securely attached.

Ensure all bolts and nuts are hand-tightened to maintain a clean and stable finish.

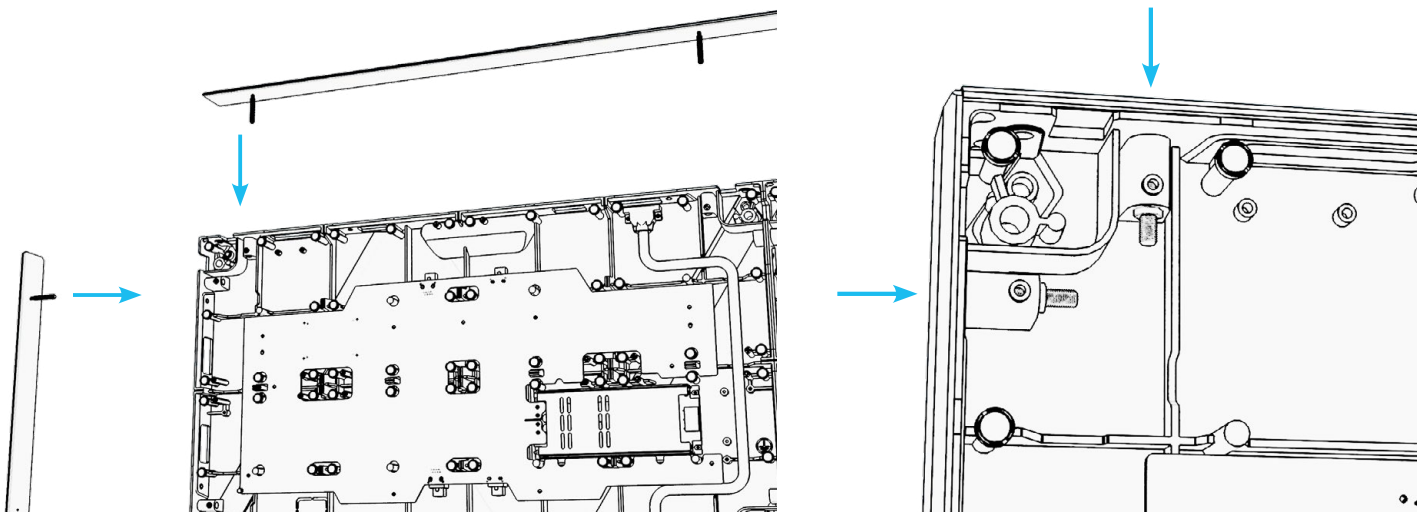

## Step 14: Connect Main Power

**PARTS NEEDED:** 1 x Main Power Cable

To connect the main power feeds to the Collaborate wall, follow these steps:

1. Locate panels 4-4. Identify the cable access hole cover in the bottom corner at the back of the panel. You will find a Taylorleds specification label covering this access point.
2. Using a screwdriver, carefully remove the cable access hole cover from inside the panel to allow access for wiring connections.

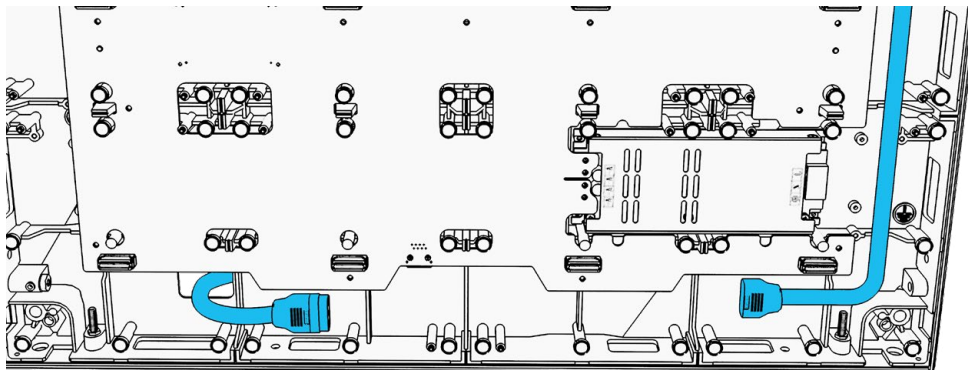
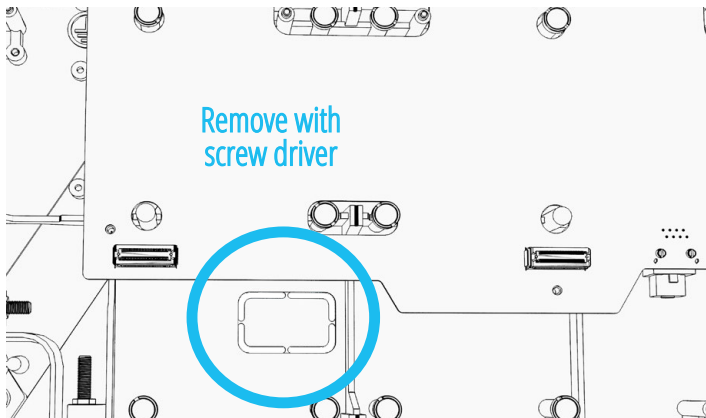

Run main power cable through access hole. Connect one end of the power cable to the device but leave the other end that goes into the wall outlet unplugged for now.

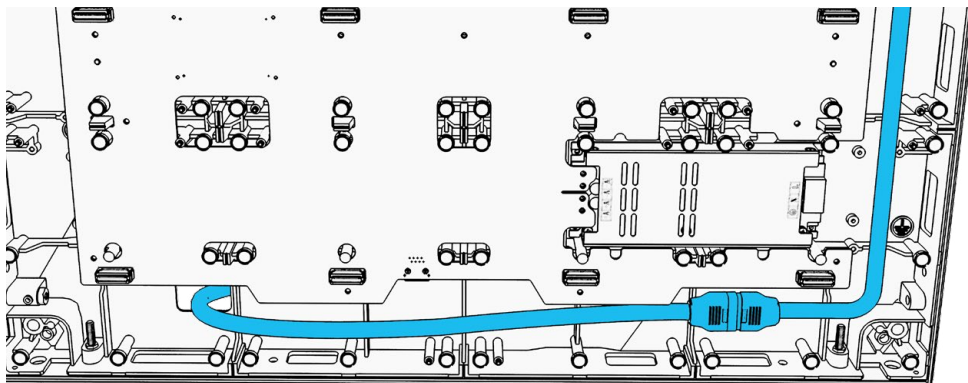

## Step 15: Connecting Power Jumpers

**PRO TIP:** Make sure to keep the jumper cables as close to the frame as possible to ensure all modules will fit onto the panel.

**PARTS NEEDED:** 4 x Power Jumper Cables (2 Female to Female and 2 Male to Male)

To connect the power to the panels:

1. Refer to the power wiring diagram below for correct connections.
2. Install the first integrated power connector at the PM1 position as indicated in the diagram.
3. Repeat the process by using the internal power connectors and jumper cables.

### POWER WIRING FRONT ELEVATION

Scale: 1:12

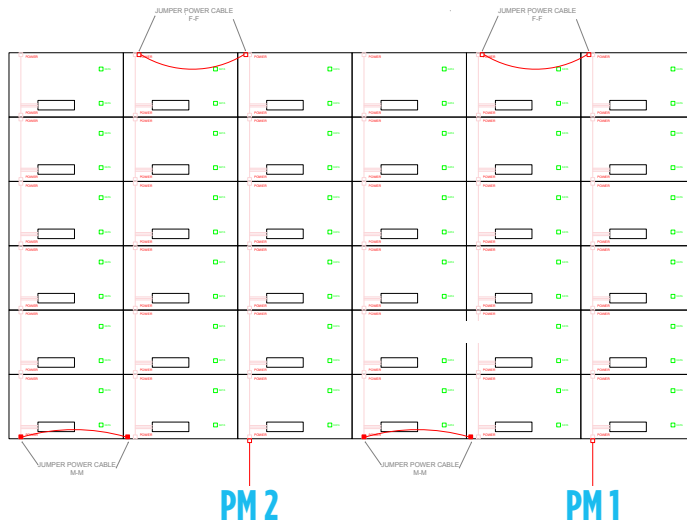

PM = POWER MAIN CABLE - PROVIDED BY ATS PRO

**TOTAL POWER:** 1X DEDICATED 20A/120V CIRCUITS. ATS PRO PROVIDES (2) POWER MAIN CABLES LED SCREEN IS 2077W MAX, 692W AVG.

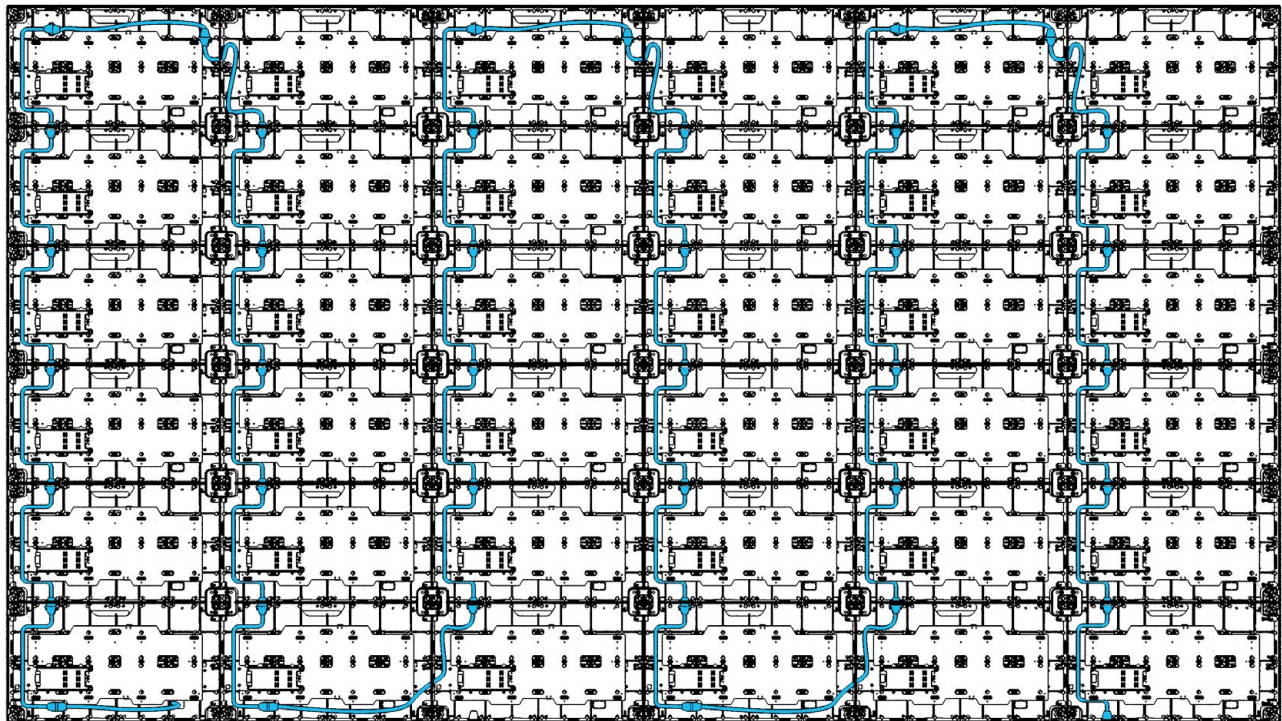

## Step 16: Connect Main Data

**PARTS NEEDED:** 6 x Main Data Cables

1. Label both ends of the five main data cables as DM1, DM2, DM3, DM4, DM5 and DM6.
2. Feed the six labeled main data cables through the accessed hole, one at a time.
3. Plug the corresponding main data cables into their respective ports (DM1, DM2, DM3, DM4, DM5, DM6).  
Refer to DATA WIRING FRONT ELEVATION Drawing.
4. Connect the power by attaching the orange-tipped power jumper cable to the main power cable.

### DATA WIRING FRONT ELEVATION

Scale: 1:15

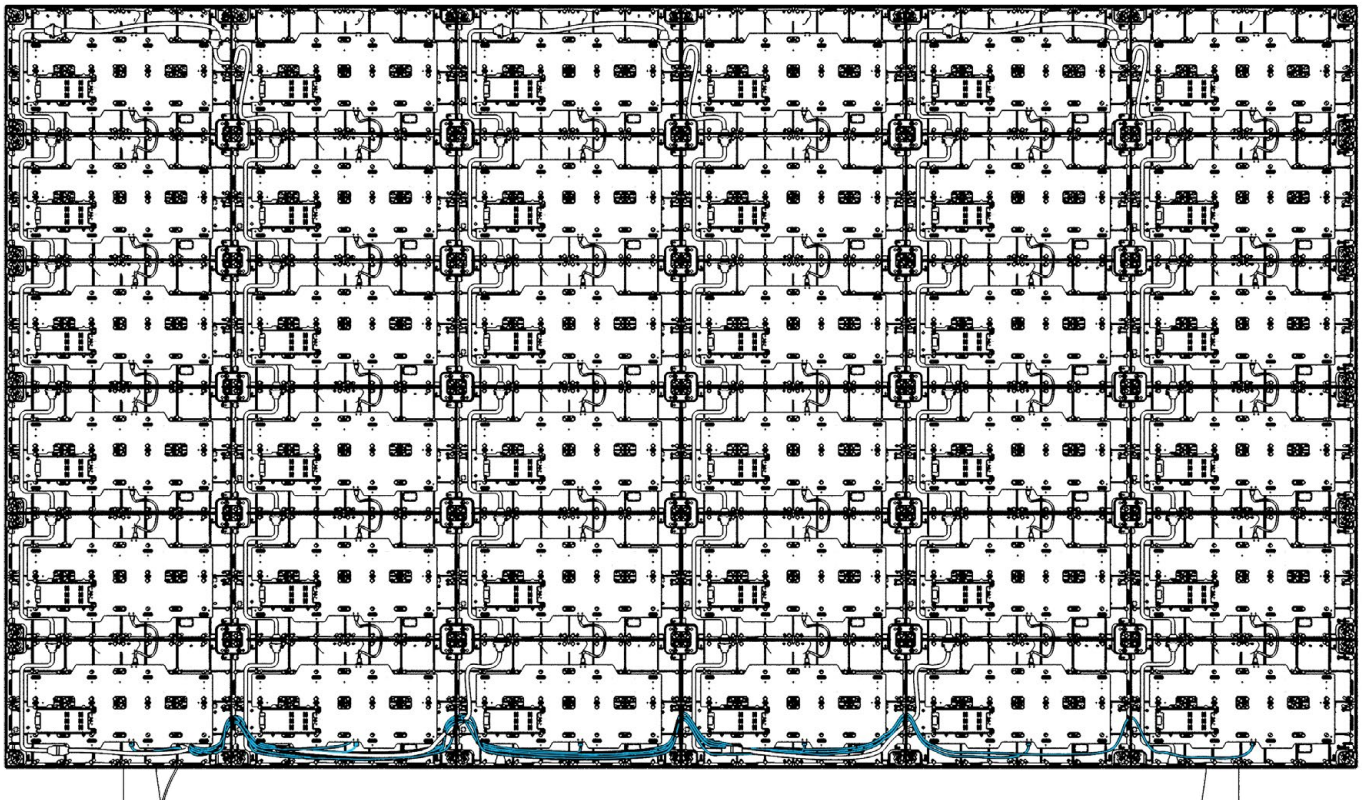
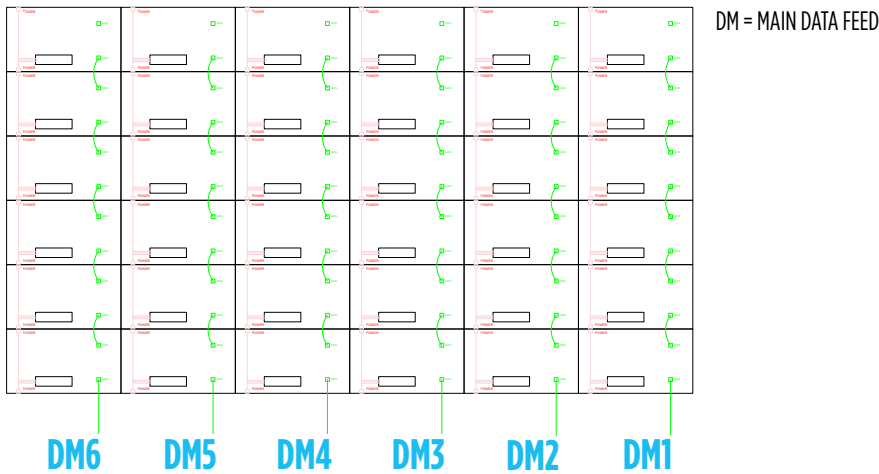

## Step 17: Connecting Data Jumper Cables

**PARTS NEEDED:** 30x Data Jumper Cables

To connect the DATA jumper cables between the panels:

1. Follow the wiring diagram for proper cable placement.
2. Install the first DATA jumper cable starting at the DM1 position.
3. Repeat the process by installing the DATA jumper cables for DM2, DM3, DM4, DM5 and DM6 as shown in the wiring diagram.

### DATA WIRING FRONT ELEVATION

Scale: 1:15

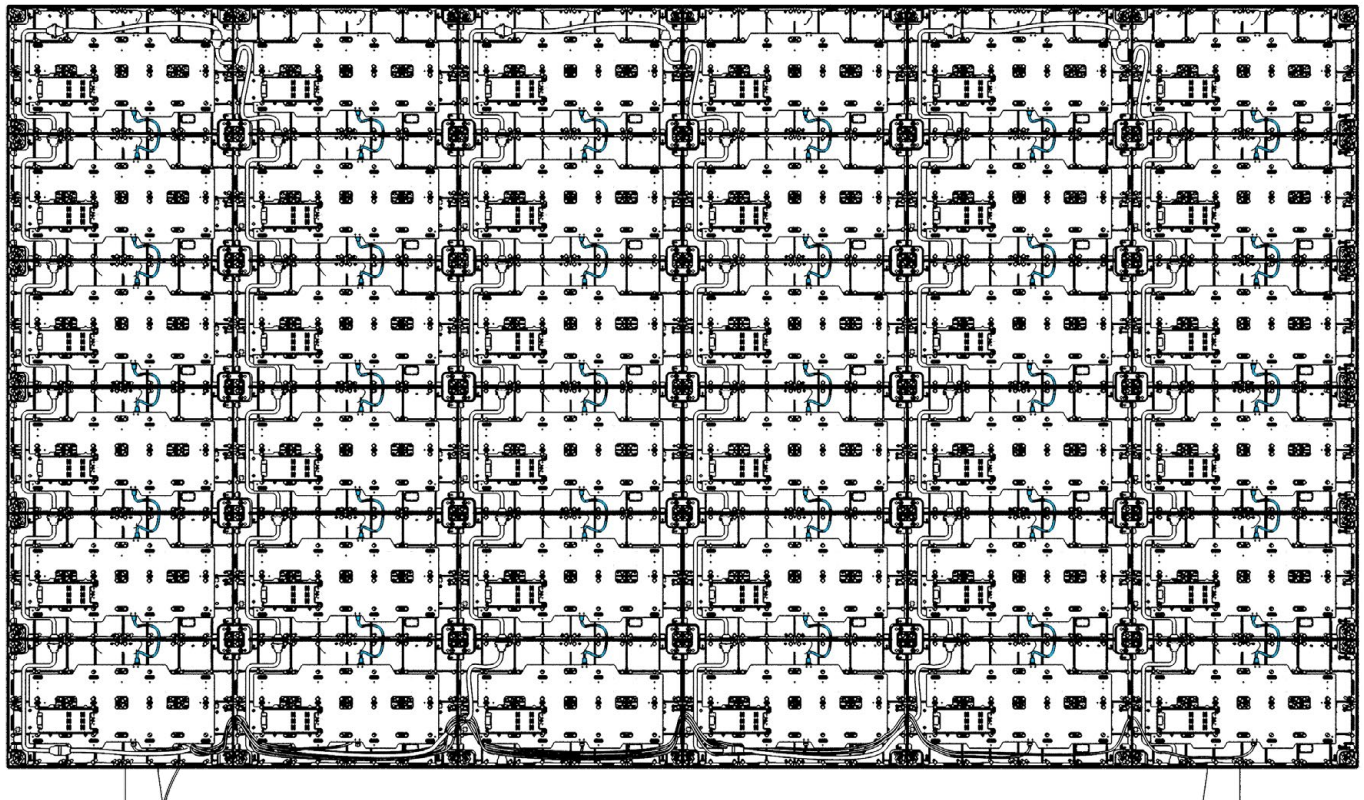
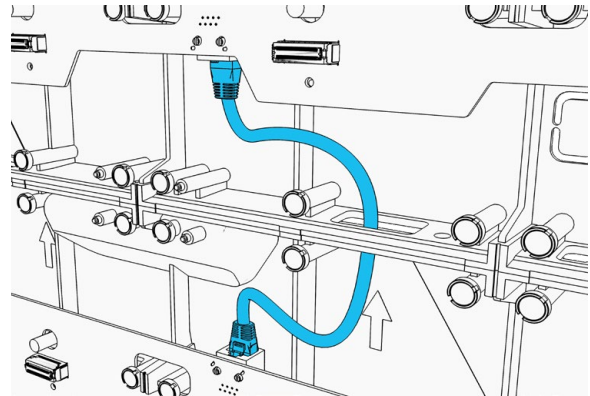
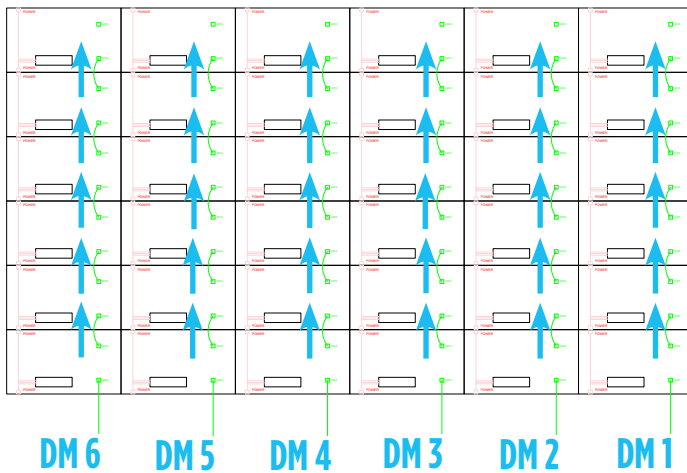

**Step 18: Connect the Processor Housing (FP0)**

TOOLS NEEDED:

PARTS NEEDED:

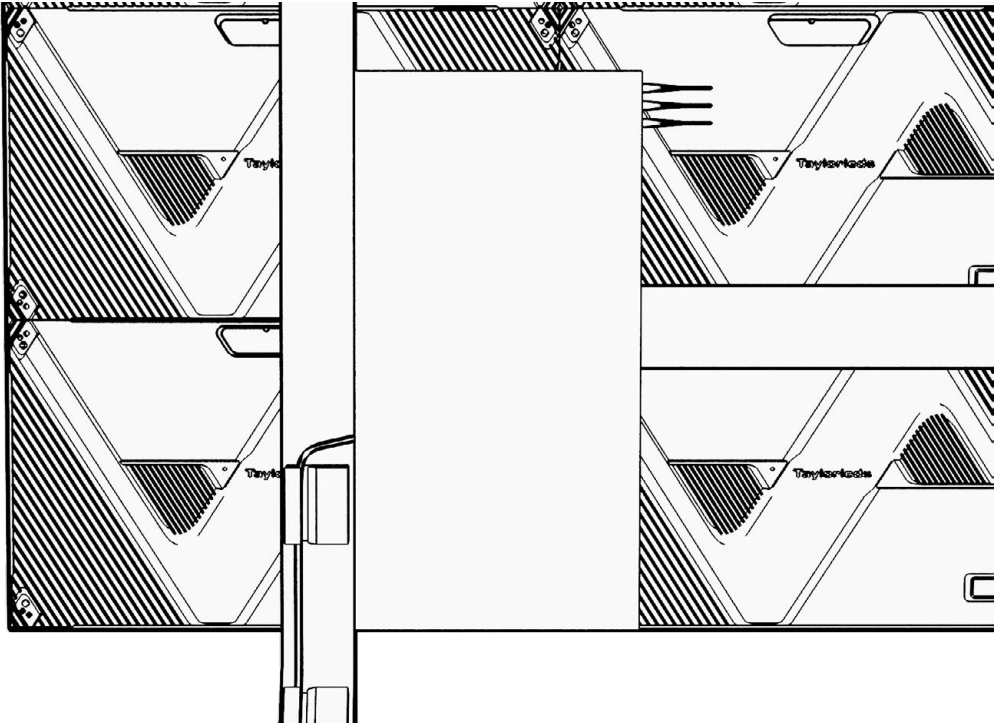
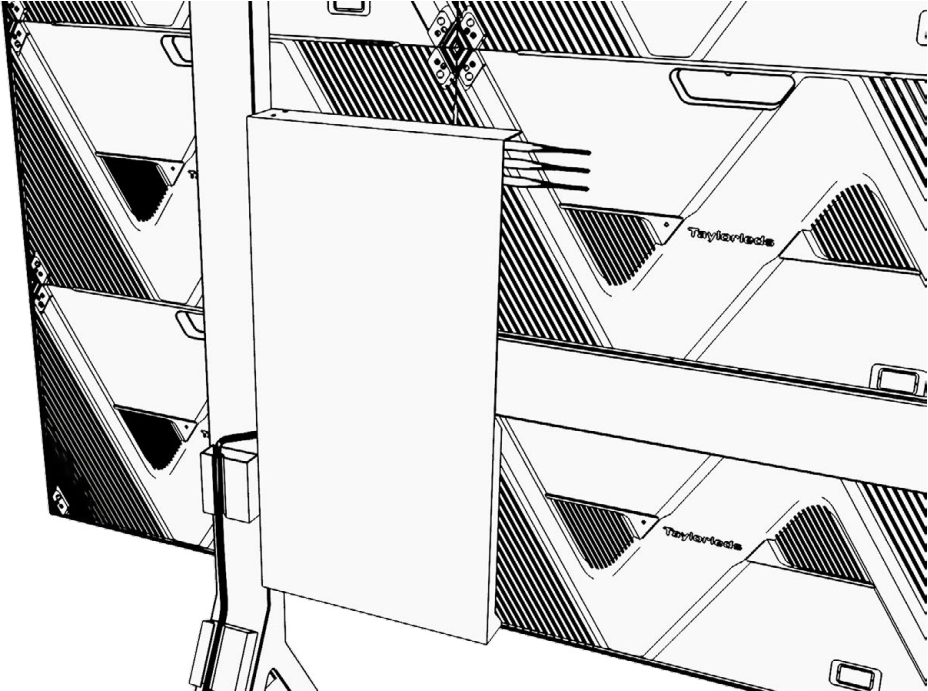

## Step 19: Connect the TU20 LED Processor

**PARTS NEEDED:** Novastar TU20

The Novastar TU20 is the system's LED processor. This allows you to map the video sources to the Collaborate wall.

On the back of the TU20, you will see six data ports. Connect the data cables (DM1, DM2, DM3, DM4, DM5, DM6) to data ports 1, 2, 3, 4, 5 and 6. See image below.

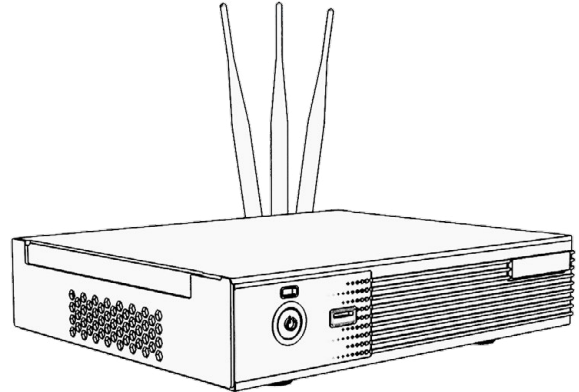
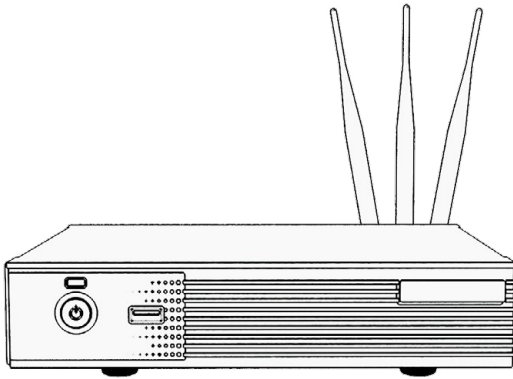
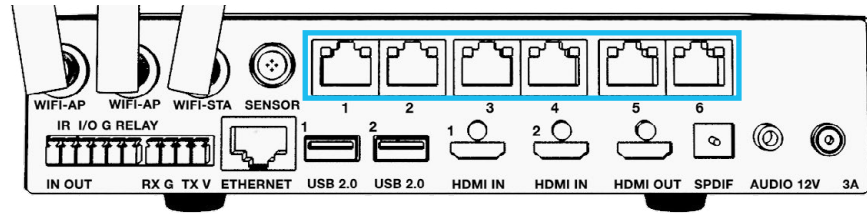

## Step 20: Starting the Collaborate Screen

The TU20 is shipped with all the necessary screen settings files to manage the pixel mapping for your 163" Collaborative system.

- 1) Plug the power cord to an AC outlet.
- 2) Install the three WiFi antennas.
- 3) Install batteries in the TU20 remote.
- 4) Press the power button on the front of the TU20.

Once the TU20's power light illuminates, allow 2 minutes for the Novastar TU20 desktop to be displayed. Use the remote control to navigate the system interface. By default, the remote is set to IR, like your typical TV remote. You also have the option to connect the remote via Bluetooth. Refer to the TU20 manual for instructions.

For details on how to use TU20 Pro, refer to the TU20 Pro manual on the included USB drive or [click here](#) to download it.

You can also watch a demonstration video [here](#). If you need support, contact [support@ats-pro.com](mailto:support@ats-pro.com).

## Step 21: Installing the Modules into the Panels in the Proper Order

**TOOLS NEEDED:** Gloves

**PARTS NEEDED:** LED Modules

**PLEASE NOTE:** Direct view LED modules are extremely fragile. Please make sure the members of your installation team understand that, from unpacking to installation, care must be taken to avoid damage. Pixel outages on new modules do happen and, in some cases, may be sent to ATS-Pro for warranty repair, for a period of two years. However, multiple missing pixels, and edge or corner damage is typically the result of mishandling and may incur a repair fee or render a module unrepairable.

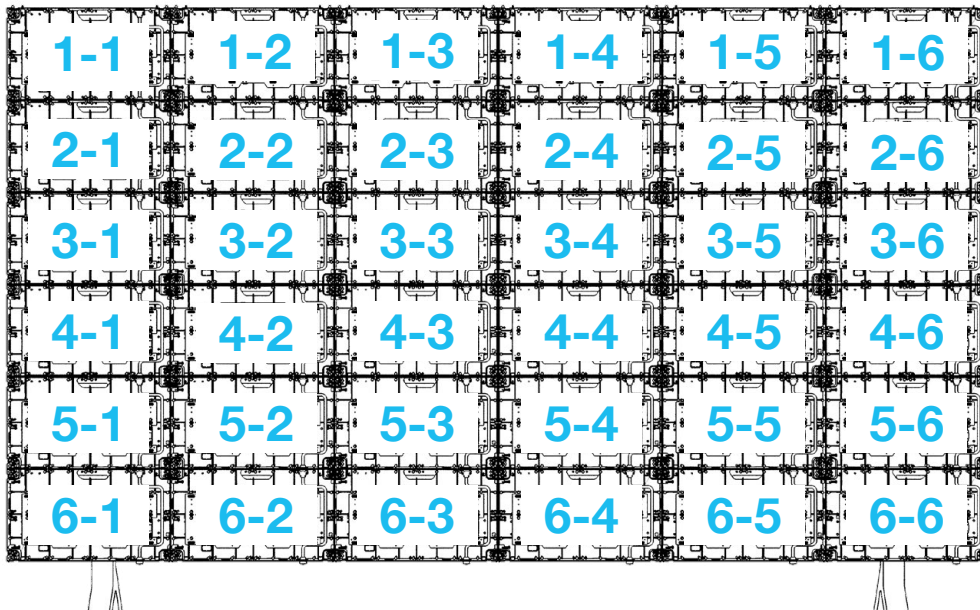

To install the COB modules, follow these steps:

1. Each module has an arrow indicating the top, similar to the panels. Ensure the arrow is pointing upwards during installation.
2. Each module is marked with a sticker that identifies its specific position on the wall. Ensure you install each module in the correct location.

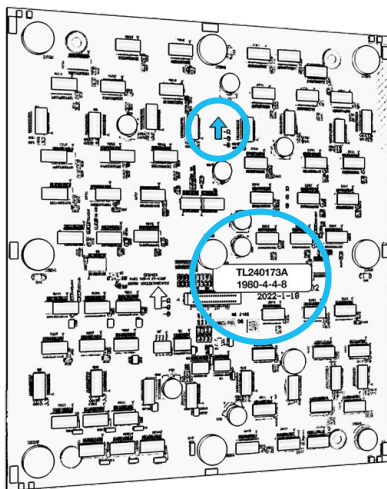

### 6-6-8

6-6-refers to the bottom right panel.  
The 8 refers to the 8th module in the panel. Which is also bottom right.  
Refer to drawing.

3. Each panel holds eight COB modules, which are packed in vacuum-sealed bags with four modules per bag.
  - Lay the bag flat before opening to prevent the modules from falling out of the foam packaging.
  - Wear the provided gloves when handling and installing the modules to avoid damage and finger prints.

4. Begin installation from panel 6-6 on the guide below. Find the box that says 6-1 to 6-6. Carefully remove the modules from the bag and flip them over in the foam holder to see the module numbers. Find the bottom right corner module to start; this should be module 6-6-8.

The modules are drawn to the panels with magnets and a data connector. Line up the corner and slowly move it towards the panel. The module will click into place.

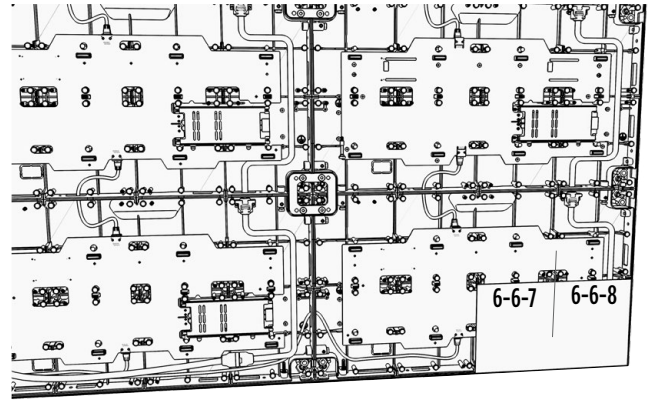
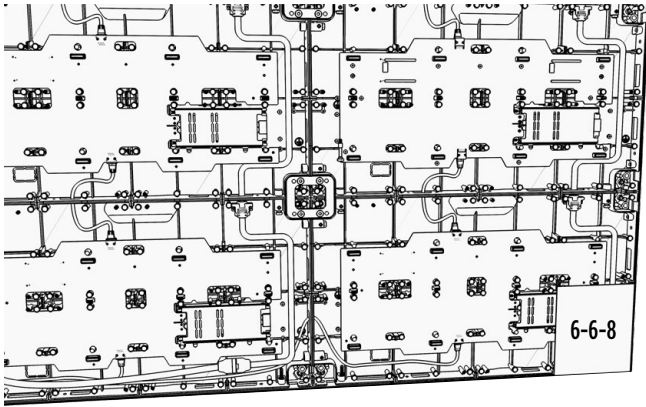

In reverse order and moving from right to left, continue to install remaining modules from the first bag. This would be 6-6-7, 6-6-6, and 6-6-5. Then open the next bag which should have modules 6-6-4, 6-6-3, 6-6-2, and 6-6-1. That will complete the first panel.

Follow these steps for the remaining panels. The next panel will be 6-5. The first bag should start with module 6-5-8 and continue in reverse order as shown.

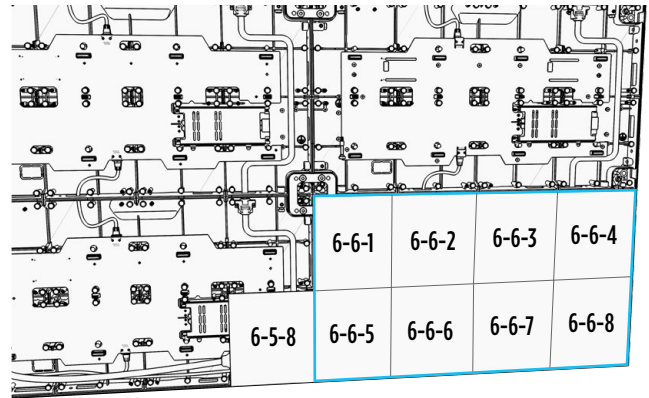
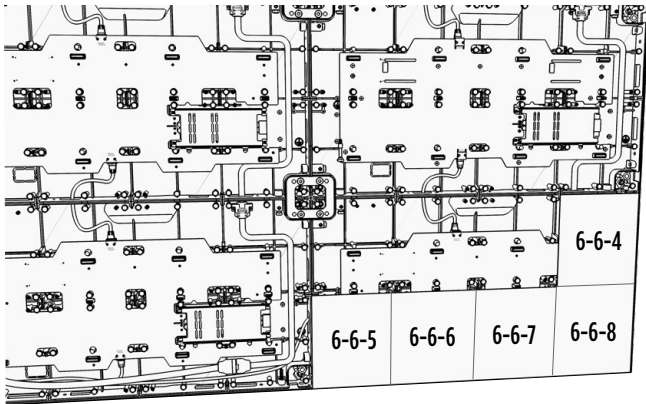

When the first row (6-1 through 6-6) is complete, start with the next row above, in this case it would be 5-6-8.

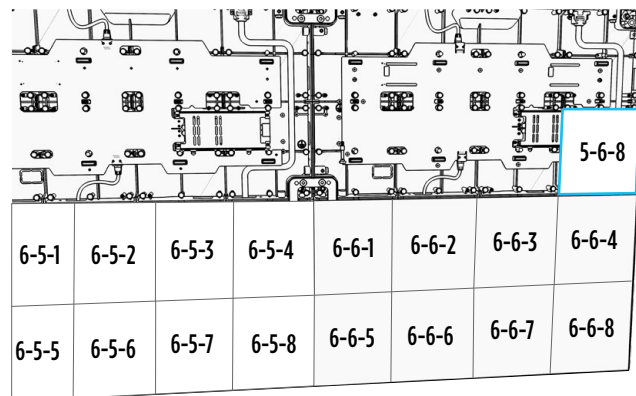

Before you start It is highly recommended to watch this [video](#) to view a demonstration of how this is done.



### Notes:

# FRONT MODULE MAINTENANCE STEPS

## Module Maintenance

### 1. Remove Module

Remove the damaged module using the module service tool, then replace with a new module.

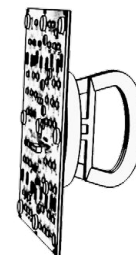
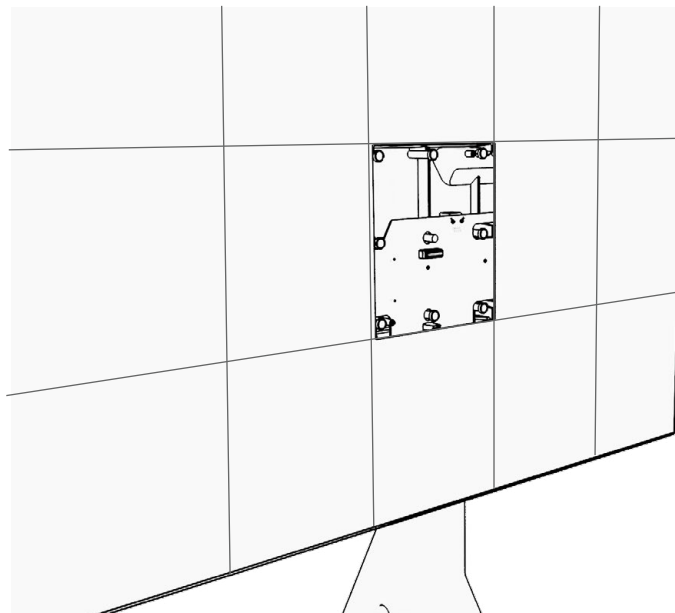
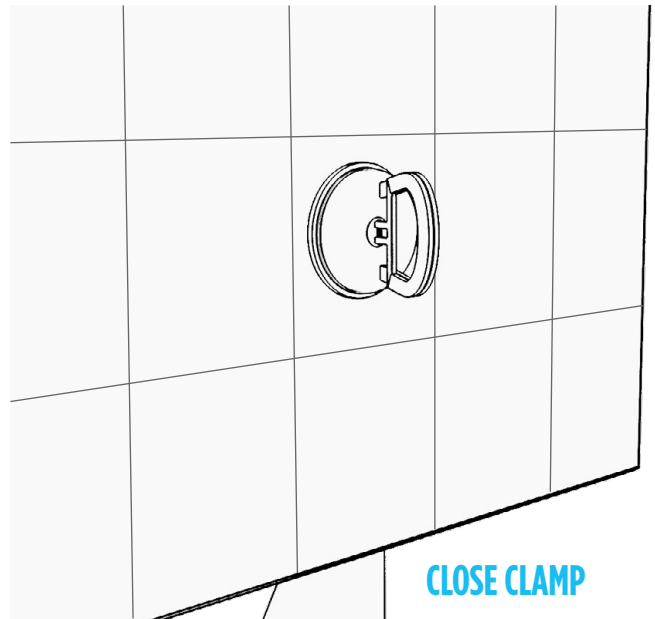
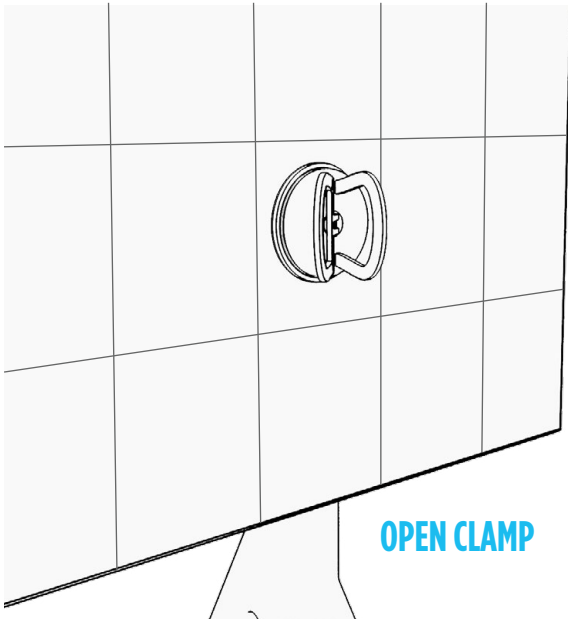

# FRONT MAINTENANCE STEPS

## Replacing the Power Supply

Note: Before you begin, make sure main power is disconnected.

### 1. Remove Modules

Remove all the modules from the panels.

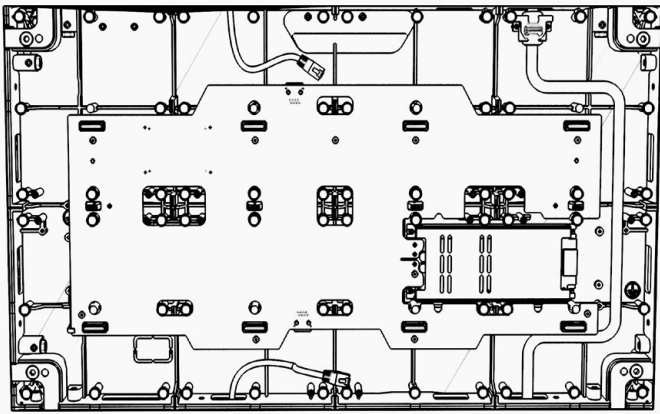

### 2. Remove Screws

Remove the connection screws and opaque 9 volt molex connector.

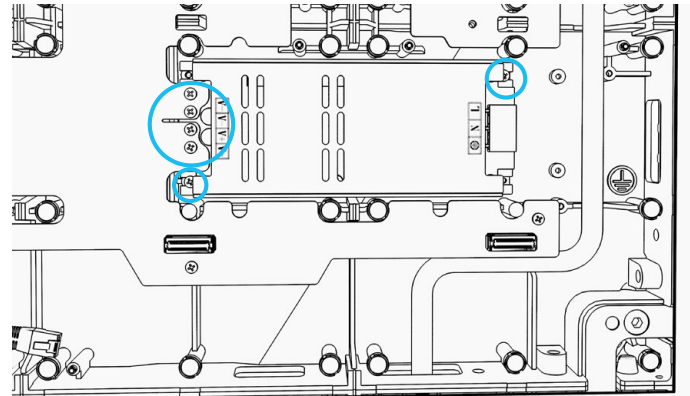

### 3. Replace Power Supply

Replace the power supply, return all screws and modules.

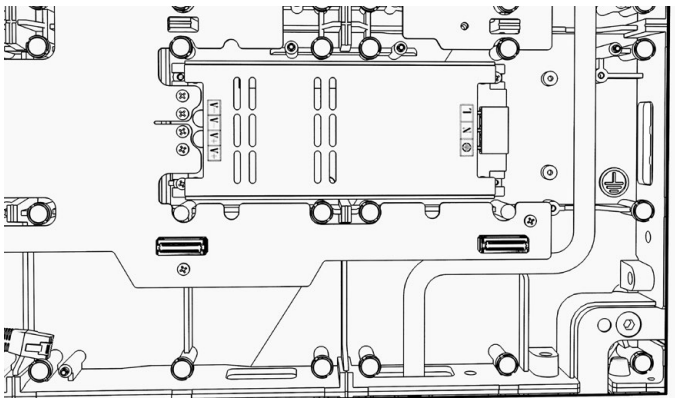

# FRONT MAINTENANCE STEPS

## Hub Card Maintenance

Note: Before you begin, make sure main power is disconnected.

### 1. Remove Modules

Remove all the modules from the damaged cabinet.

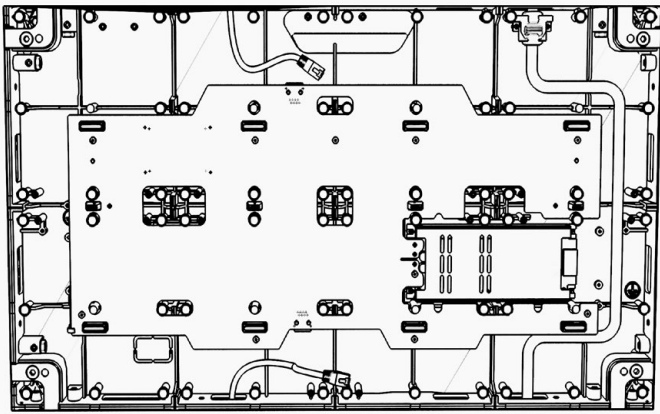

### 2. Remove Receiving Card

Remove the connection screws to replace the receiving card.

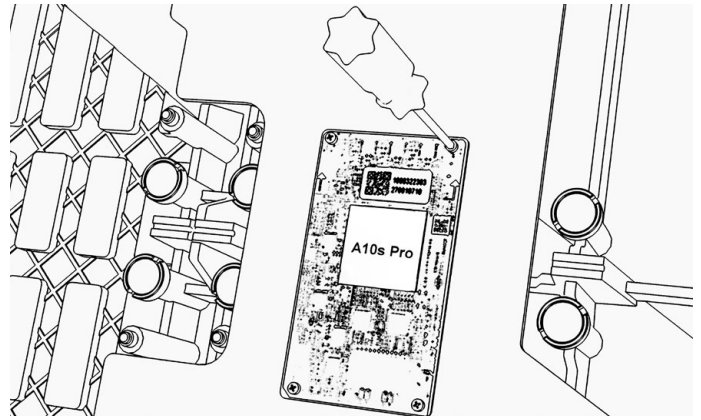

### 3. Remove Screws

Remove the connection screws and current wire to replace the HUB board.

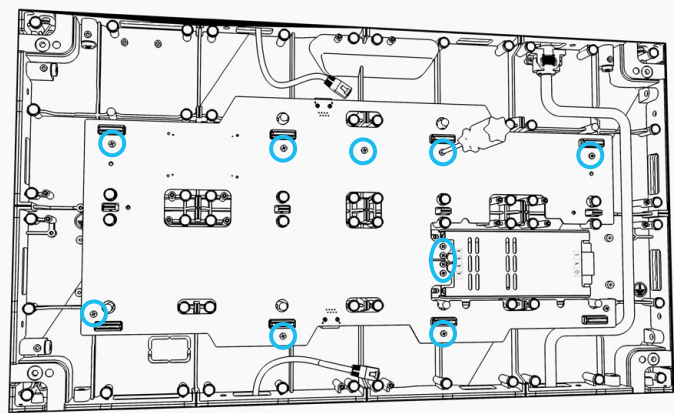

### 3. Replace HUB Board

Replace the HUB board, return the screws, reinstall receiving card, and all modules.

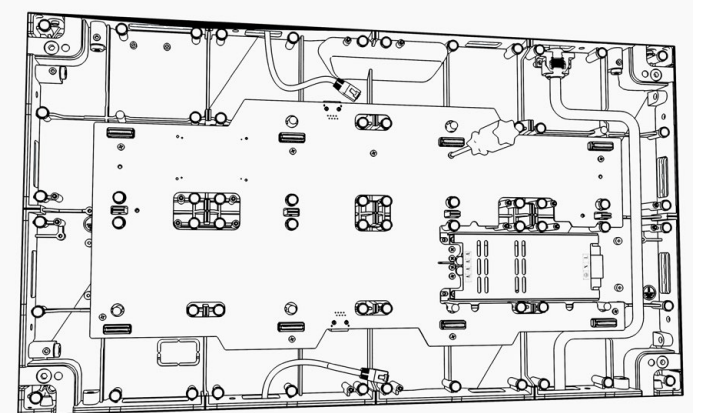

# LED WARRANTY:

Contact your ATS-Pro reseller to report a warranty claim.

---

**Learn More**

[ats-pro.com](https://ats-pro.com)

**Contact Us**

1-800-755-3235 | [info@ats-pro.com](mailto:info@ats-pro.com)    **Support** 1-800-755-3235 ext. 1 | [support@ats-pro.com](mailto:support@ats-pro.com)

**Follow Us**

[in linkedin.com/company/atsproled](https://www.linkedin.com/company/atsproled) [ig instagram.com/atsproled](https://www.instagram.com/atsproled) [f facebook.com/atsproled](https://www.facebook.com/atsproled) [x @atsproled](https://twitter.com/atsproled)

