

1) Using a 2nd person, lift the rack to the desired location, level, and mark all mounting holes with a pencil. Set rack aside.

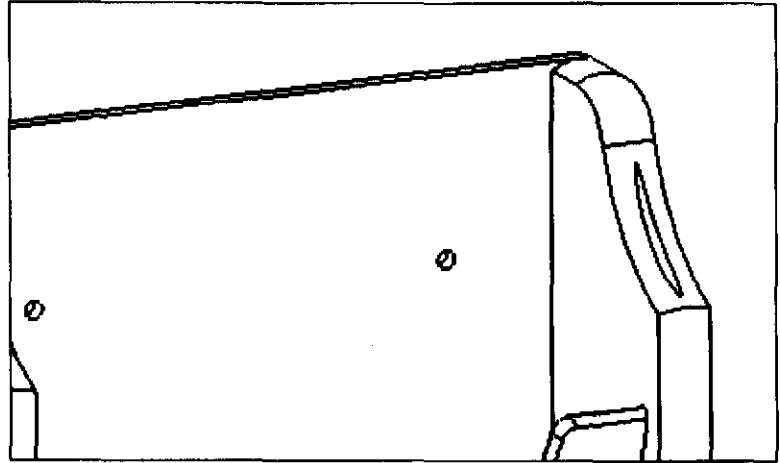

2) Using a power drill, drill a hole slightly larger than the barrel of the wall anchor.

PLEASE NOTE: WALL ANCHORS ARE MEANT FOR WALL SURFACES FROM 3/8" TO 5/8" THICK.

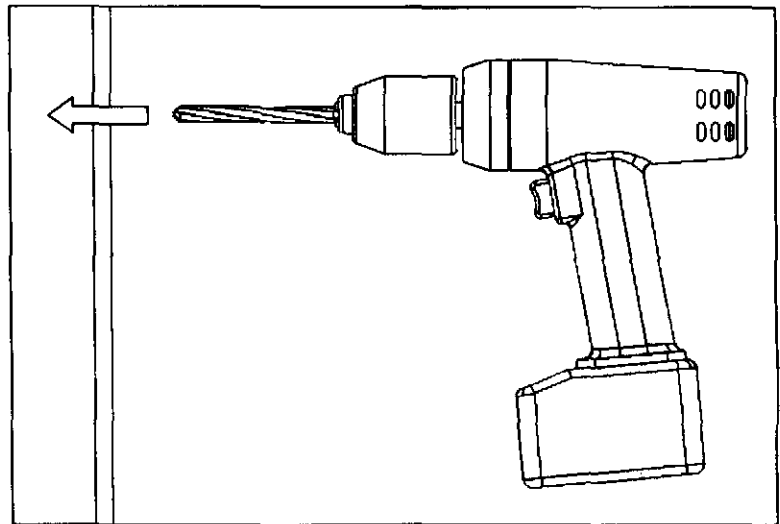

3) Insert the wall anchor into the wall and tap the head, using the butt end of a screwdriver or small hammer, until the gripper prongs are embedded into the surface of the wall.

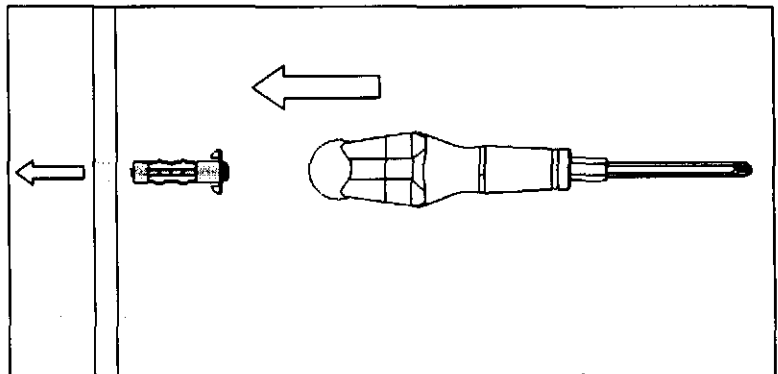

4-A) Press down firmly on the head of the screw with a screwdriver and turn the screw clockwise until the barrel crimps against the inside of the wall.

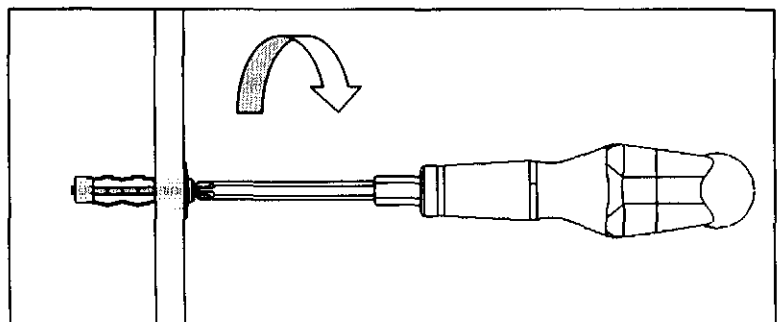

4-B) Press down firmly on the head of the screw with a screwdriver and turn the screw clockwise until the barrel crimps against the inside of the wall.

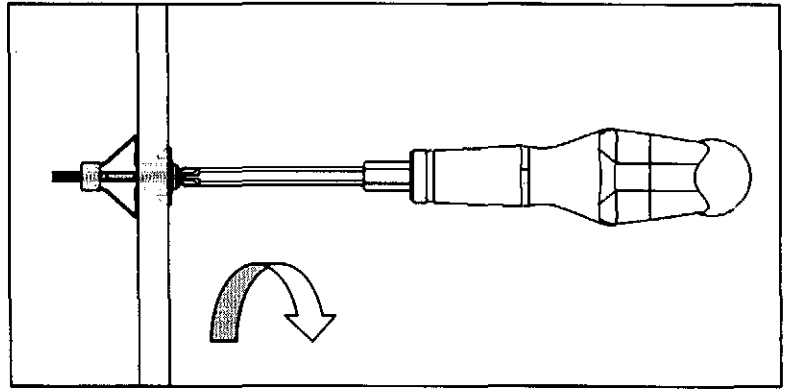

5) With the barrel pressing firmly against the inside of the wall, remove the screw by turning it counter-clockwise. If the wall anchor feels loose after removing the screw, re-insert the screw and tighten more.

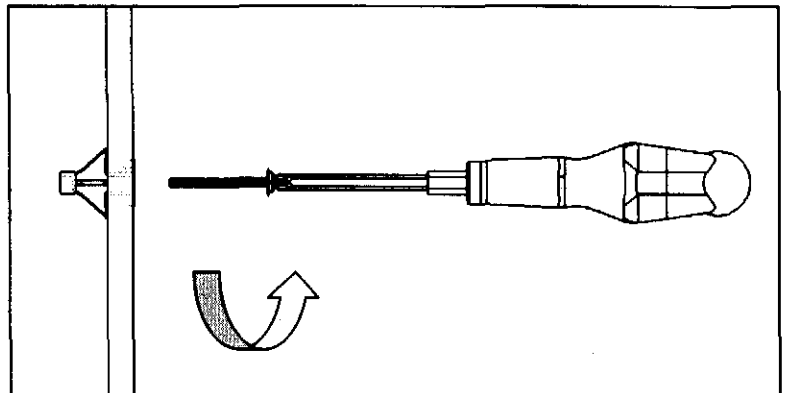

6) After the screws have been removed, line up the mounting holes on the rack with the wall anchors and re-insert the screws and tighten. (Be careful not to over tighten.)

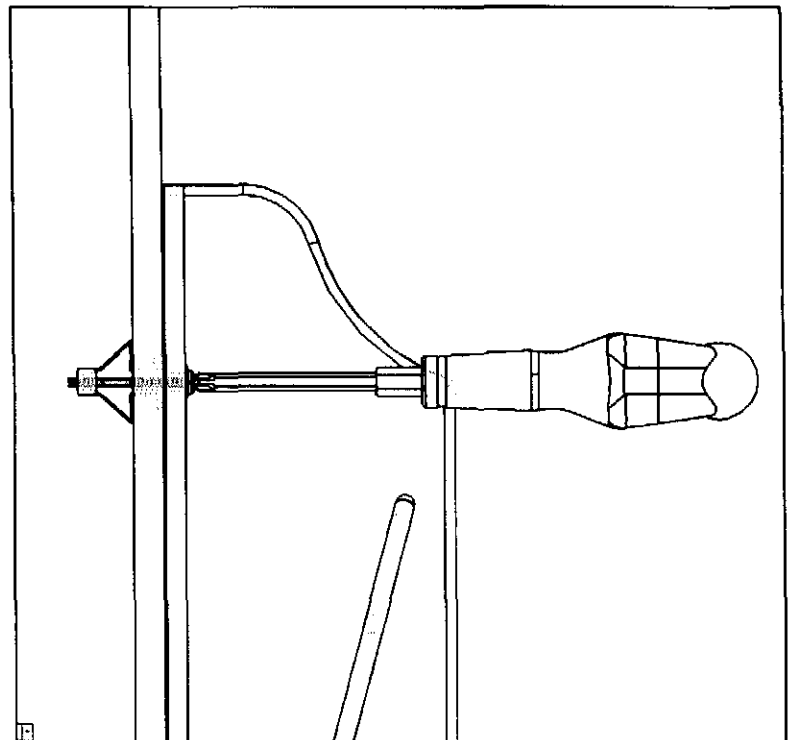

Attaching Feet To Double-Sided MG Magazine Rack

3) Insert barrel screw through each hole at top of magazine racks. From opposite face, screw machine screw into barrel screw.

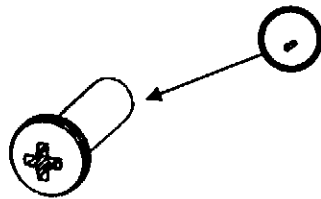

1) Begin by placing two magazine racks back-to-back and aligning the holes on the feet with the holes on the bottom of the magazine rack sides. It's suggested to lay the unit on the floor when attaching the feet.

2) Using a screwdriver, press down firmly on the head of the screw and turn the screw clockwise up into the holes on the bottom of the magazine rack side. Tighten the screws until the feet are securely attached.

