

# INSTALLATION GUIDE

## FLOOR TV Stand

### DPD-2642

Support 26" to 42" Screens

Max Load Capacity: 132 lbs (60 kg)

**VESA 100x100/200x100/200x200 compatible**

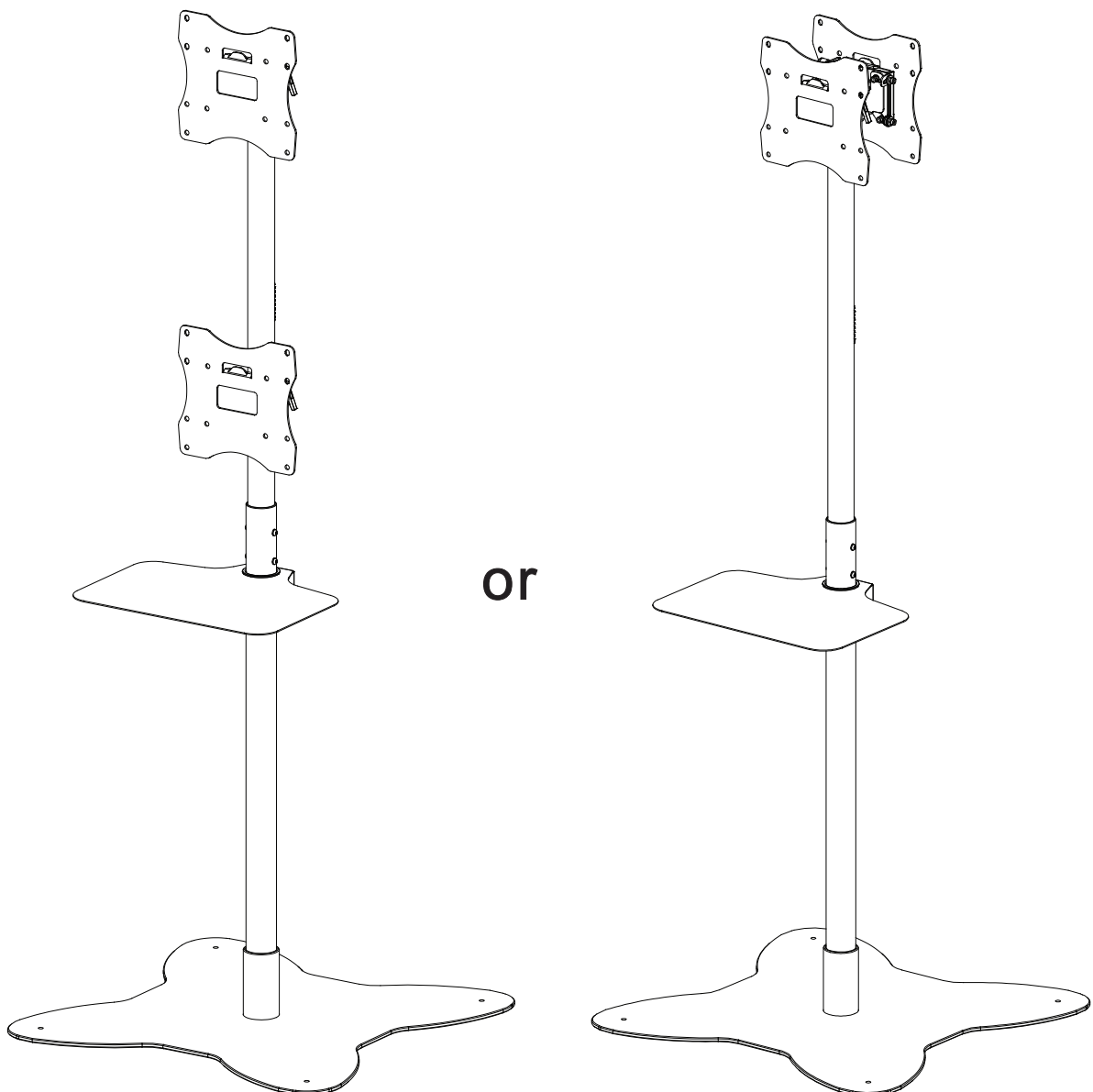

## ⚠ WARNING

- Be sure to read this entire manual thoroughly and you fully understand all the instructions and warning before attempting to begin your installation.
- This product should only be installed by someone who has a basic knowledge of building construction, installations and fully understands these instructions.
- Always have someone assist you to lift and position your equipment.
- Tighten screws and bolts firmly, but do not over tighten. Over tightening can damage the items and greatly reduce their ability to hold. Please refer to suggested torque values where applicable in these instructions.

### Tools Needed for Assembly

- level
- phillips screwdriver

### Table of Contents

- |  |   |
|--|---|
| <p>① Install the first pipe (EE) onto base floor (DD)</p> <p>② Mount the AV Tray (CC) onto the first pipe (EE)</p> <p>③ Mount the second pipe (FF)</p> <p>④ Separate the head assembly (AA)</p> <p>⑤ Mount the head assembly onto second pipe (FF)</p> | <p>⑥ Mounting the Assembly the adapter Plate to Screen</p> <p>⑦ Mount display</p> <p>⑧ Adjust angle</p> <p>⑨ Using cable management</p> <p>⑩ Increase the head accessory (Optional)</p> |
|--|---|

### A. Installation hardware kits

#### 1. For TV's

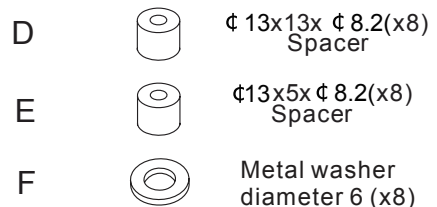
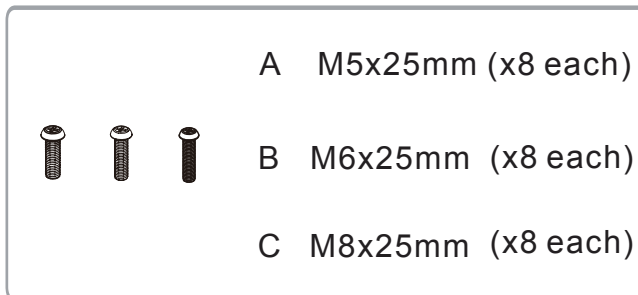

#### 2. For installing the stand cart

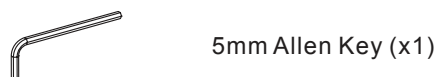
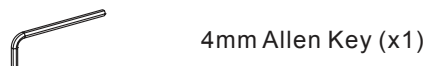
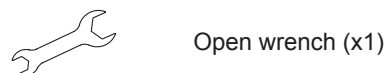
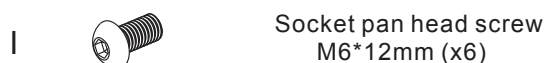

## B. Component checklist

**AA(X2)**  
(Head Assembly)

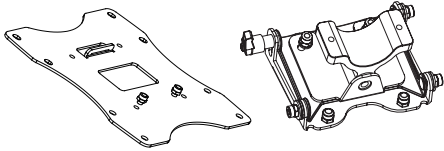

**BB(X2)**  
(Locking Block)



**CC(X1)**  
(AV tray)

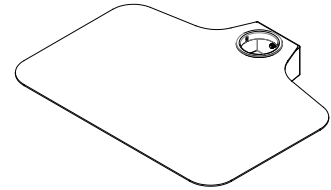

**DD(X1)**  
(base floor)

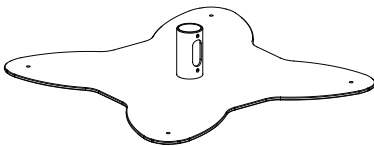

**EE(X1)**  
(First Pipe)

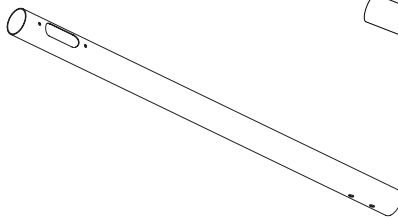

**FF(X1)**  
(Second Pipe)

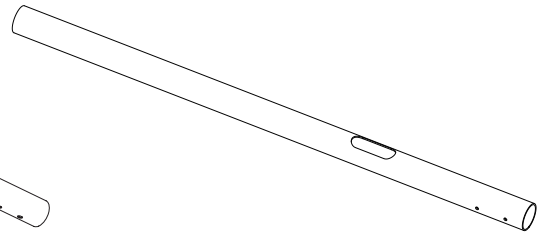

**1**

**Install the first pipe (EE) onto base floor (DD)**

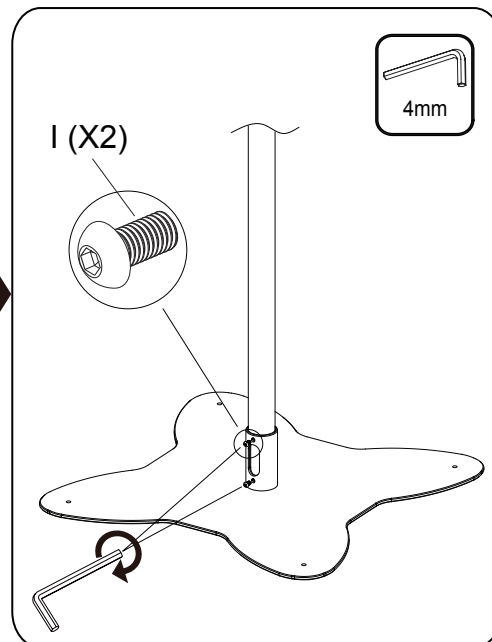
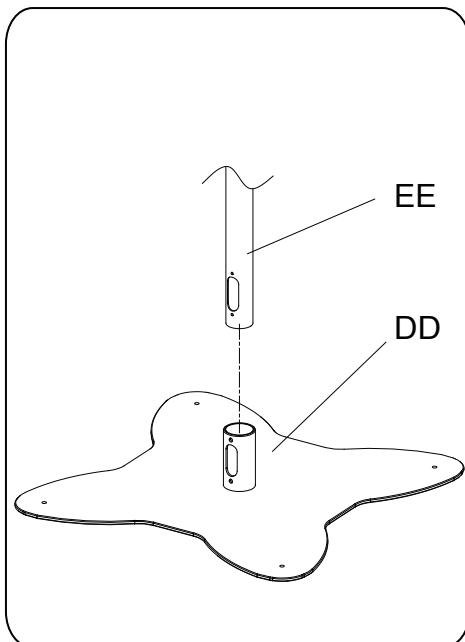

2

## Mount the AV tray (CC) onto the first Pipe (EE)

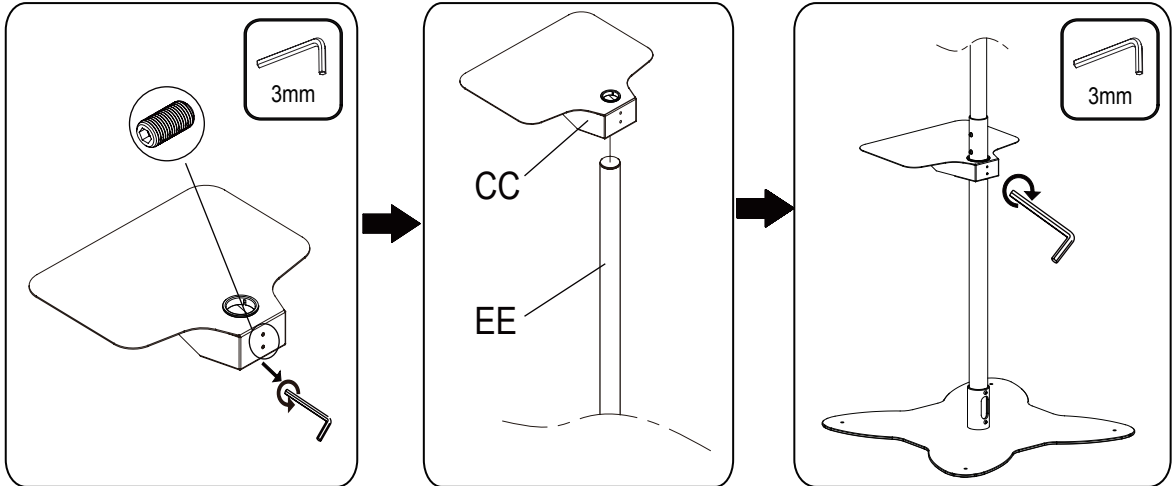

3

## Mount the second pipe (FF)

Mount the second pipe (FF) onto the first pipe (EE).

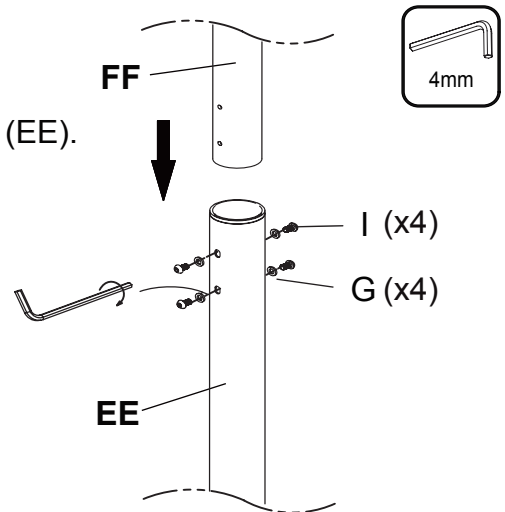

4

## Mount the Head Assembly onto second pipe (FF)

A. Vertical

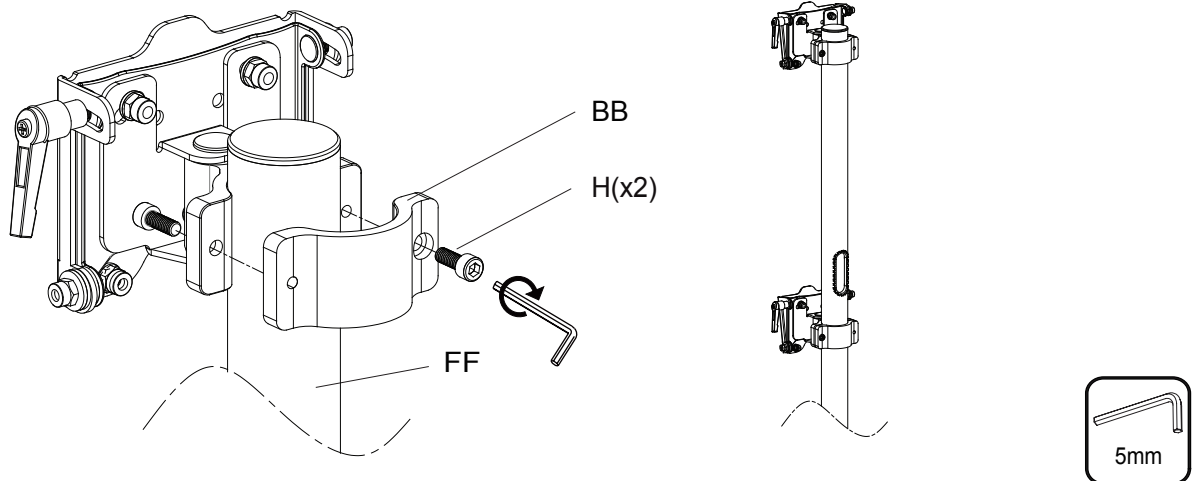

## 4 Mount the Head Assembly onto second pipe(FF)

B.Back to Back

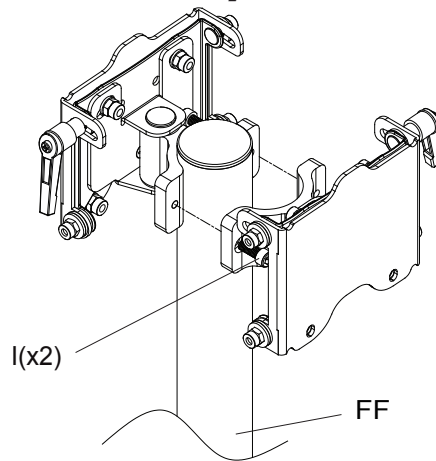

5mm

## 5 Mounting the assembly the adaptor plate to screen

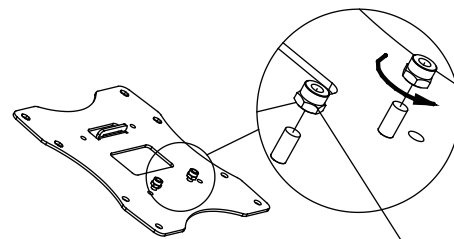
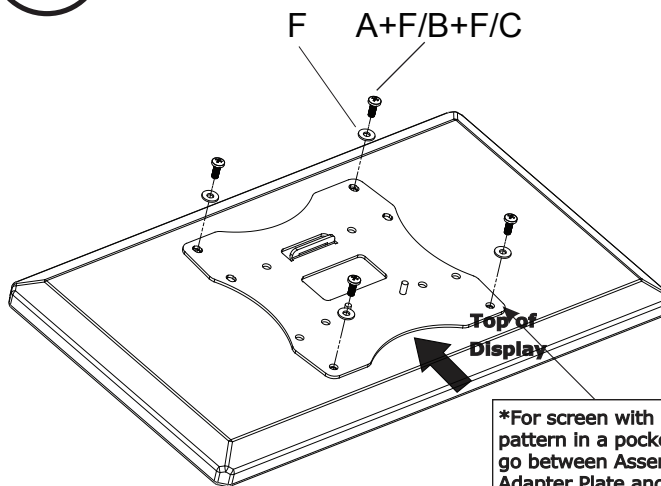

Screw off the nut first.

### Note:

Recessed Mounting Holes.  
If the mounting holes are recessed into the back of the display, use the supplied spacer to pack the recessed hole. Ensure that the brackets are securely fixed to the display.

\*For screen with a hole pattern in a pocket, spacer go between Assembly 200x200 Adapter Plate and screen.



## 6 Mount display

Mount the universal adapter kit onto display .

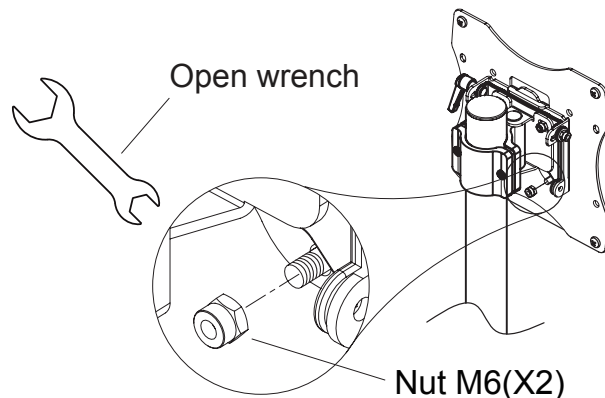
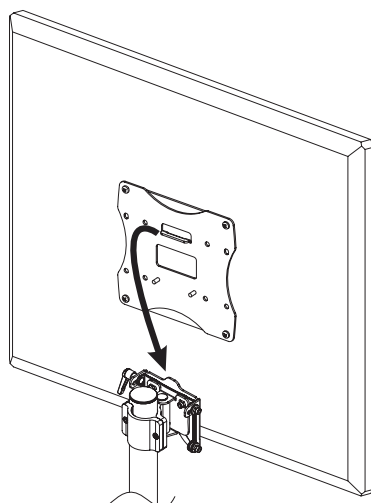

7

### Adjust angle

Second person will be required to assist !

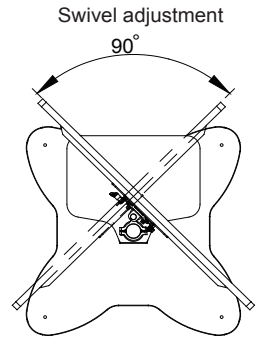
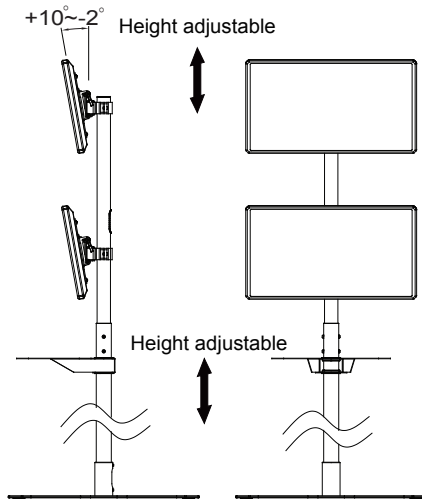
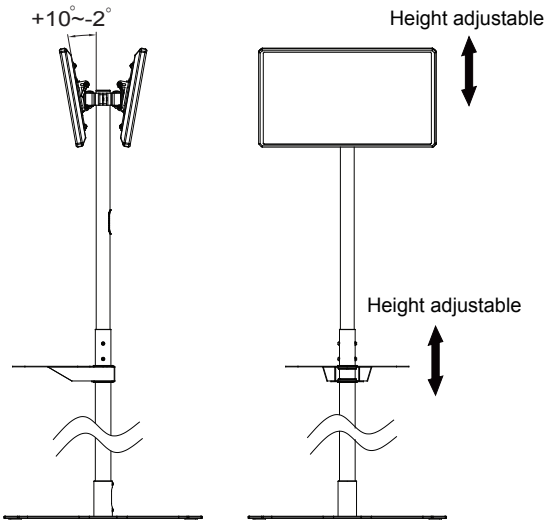
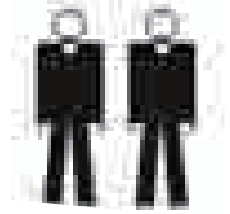

8

### Using cable management

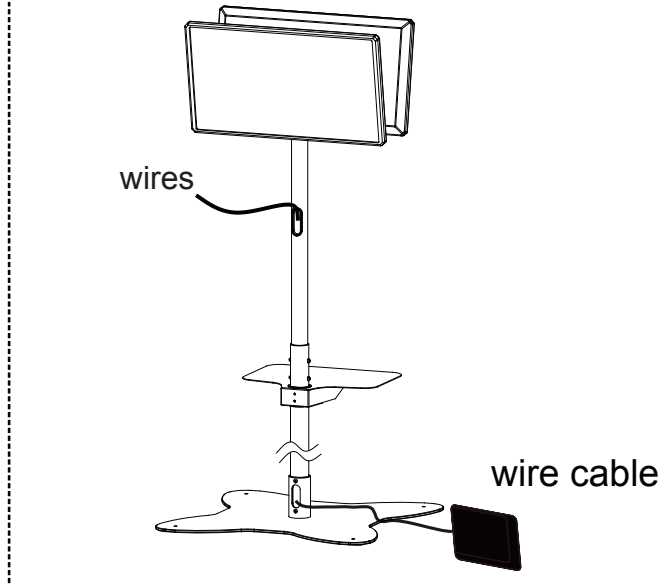
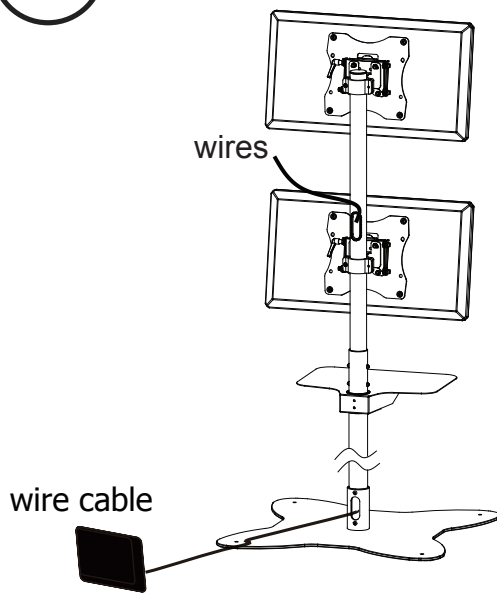

9

### Support 4 screens installation(option)

