

Vector Frame Kit 15

VF-K-15

The innovative, contemporary and clean appearance of the Vector Frame™ line of exhibit kits will captivate your audience. Kits feature push-fit fabric graphics, easy-to-assemble extrusion frames, accent lighting, tables, counters, literature accessories, monitor mounts and interior LED edge lighting where indicated.



features and benefits:

- 50mm silver extrusion frame
- Illuminated graphic panel with interior LED lighting top and bottom
- Single-sided SEG dye-sublimated push-fit fabric graphics
- Kit includes frame, one illuminated fabric graphic panel, four rigid graphic accents, and one wheeled molded case
- Lifetime hardware warranty against manufacturer defects

dimensions:

Hardware	Graphic
<p>Assembled Unit: 112" w x 95" h x 19.75" d 2845mm(w) x 2413mm(h) x 501.75mm(d)</p>	<p>Total visual area: Center graphic area: 94.5" w x 94.5" h 2400mm(w) x 2400mm(h)</p> <p>Accent wings: 8.26" w x 45.27" h 210mm(w) x 1150mm(h)</p>
<p>Shipping</p> <p>Shipping Dimensions - ships in 1 case: 1 OCH2 case: 52" l x 30" w x 15" h 1320mm(l) x 760mm(w) x 380mm(h)</p> <p>Approximate shipping weight (entire kit): 110.25 lbs / 50 kgs</p>	<p>Please be sure to include a 2" bleed around the perimeter of the center graphic and a 1/2" bleed around the perimeter of all wing graphics.</p> <p>Refer to related graphic templates for more information</p>

additional information:

Graphic Material:
Dye-sublimated fabric

We are continually improving and modifying our product range and reserve the right to vary the specifications without prior notice. All dimensions and weights quoted are approximate and we accept no responsibility for variance. E&OE. See Graphic Templates for graphic bleed specifications.

Parts Included:

Code	Qty	Description
VF-K-15-A-G	x1	210MM (8.26")W X 1150MM (45.27")H PVC GRAPHIC
VF-K-15-B-G	x1	210MM (8.26")W X 1150MM (45.27")H PVC GRAPHIC
VF-K-15-C-G	x1	2400MM (94.5")W X 2400MM (94.5")H FABRIC GRAPHIC W/FCE-2 ALL SIDES
VF-K-15-D-G	x1	210MM (8.26")W X 1150MM (45.27")H PVC GRAPHIC
VF-K-15-E-G	x1	210MM (8.26")W X 1150MM (45.27")H PVC GRAPHIC
VF-K-15-F-G	x1	2400MM (94.5")W X 2400MM (94.5")H FABRIC GRAPHIC W/FCE-2 ALL SIDES
F27	x7	1200MM LENGTH OF PHFC4 EXTRUSION - WITH MITRE CUT FOR CB9 ONE END - IB2 LOCK HOLES ONE END
F60	x1	1200MM LENGTH OF PHFC4 EXTRUSION - WITH MITRE CUT FOR CB9 ONE END - IB2 LOCK HOLES ONE END - WITH WIRE CHASE HOLE
SW-FOOT	x2	VECTOR FRAME SUPPORT FOOT
IB2	x5	PH INLINE CONNECTOR
CB9	x4	CB9 CORNER BRACKET
VE-70	x2	1155MM (45.47") PH EXTRUSION WITH LOCK ONE END
LED KIT	x2	LED LIGHTING KIT
PANEL CLAMP	x8	7MM PLASTIC MOLDED PANEL CLAMP

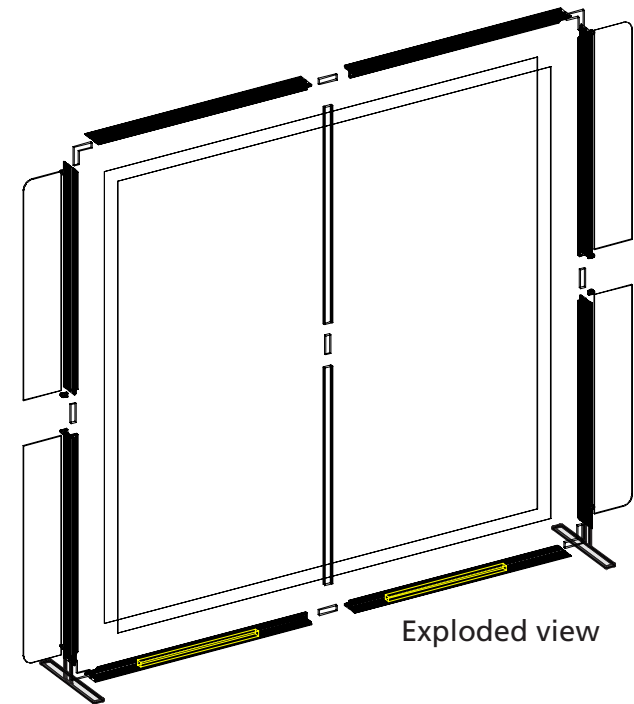
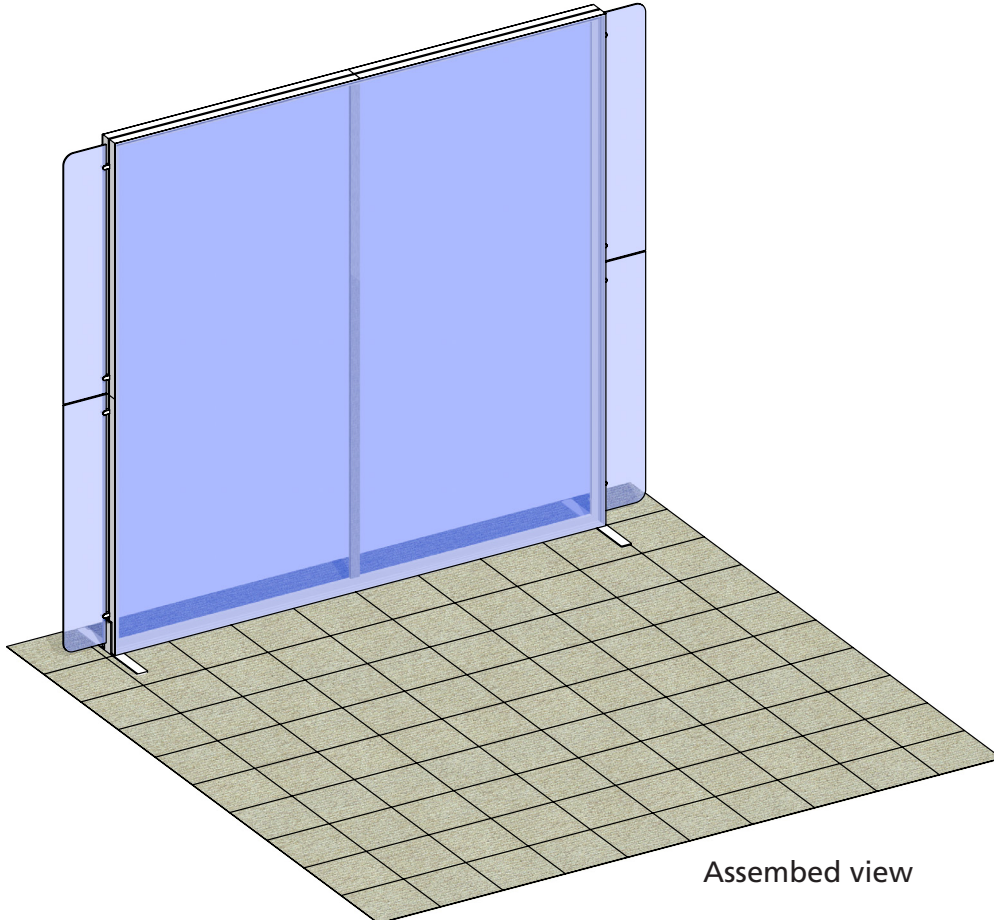

Step 1: Assemble Frame

Arrange pieces on the floor as shown in the diagram below. Assemble frame by securing CB9's to the F27s and F60. When locking be sure to turn each cam a little bit and then go back and tighten to the proper tension. Take care to turn locks only half a turn. Slide the IB2 into the extrusion to connect sides. Tighten to the proper tension to lock extrusions together. Lights come adhered to the F27s. Ensure lighting strips on top and bottom are connected.

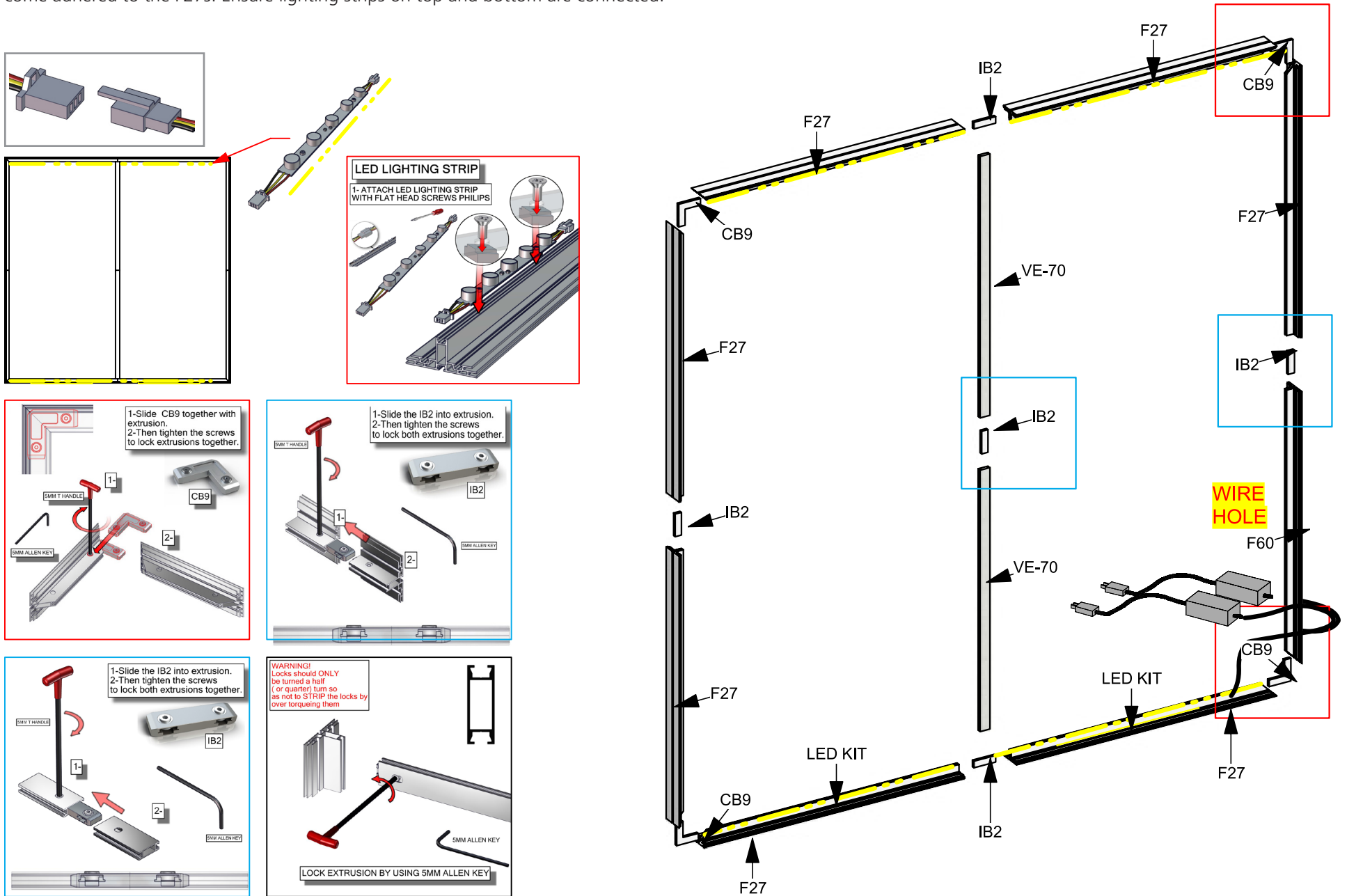

Step 2: Apply Graphics & Attach Feet

Apply graphic(s) by pressing the FCE-2 edge of graphic into the channel of the extrusion. Start in upper left corner, go across the top and then down the sides to the bottom. Assure each graphic is tightly inserted. When taking graphics off, take care to gently pull by attached pull tab. To adhere foot to frame, loosen thumbscrews from foot. Slide extrusion into LN-100 groove. Tighten to the proper tension to secure supporting feet.

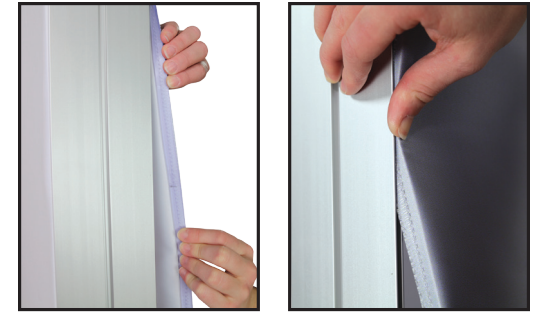
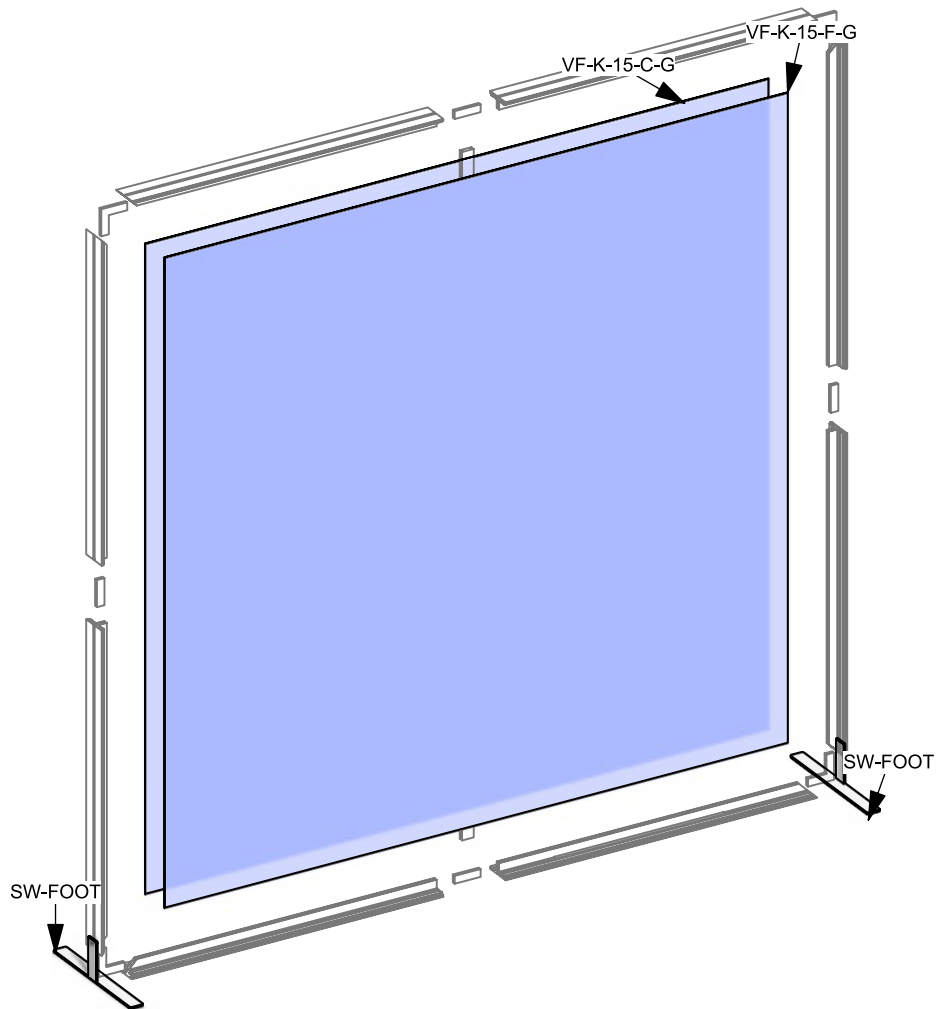

FCE-2 TO PHFC4

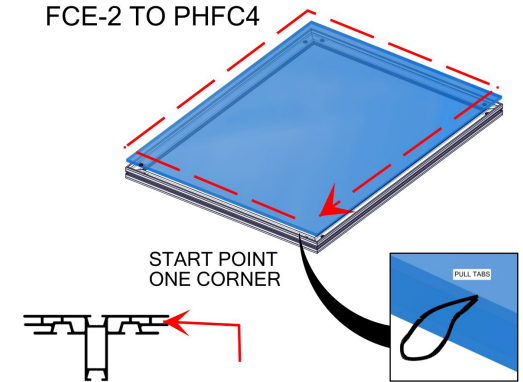

Install graphic by pressing the FCE-2 into the channels of PHFC4 extrusion. To pull graphics out of the channels, use tabs on the front side

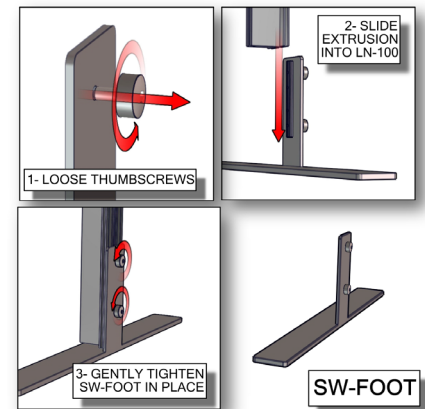

Step 3: Attach Accent Wings

To attach accent wings, screw panel clamp clockwise, into the channel until it is tight. Loosen the thumbscrew. Place rigid sintra graphics and tighten thumbscrew to secure. Overtightening can strip thumbscrew and damage graphic. Once all graphics are in place, connect to power strip to illuminate backwall.

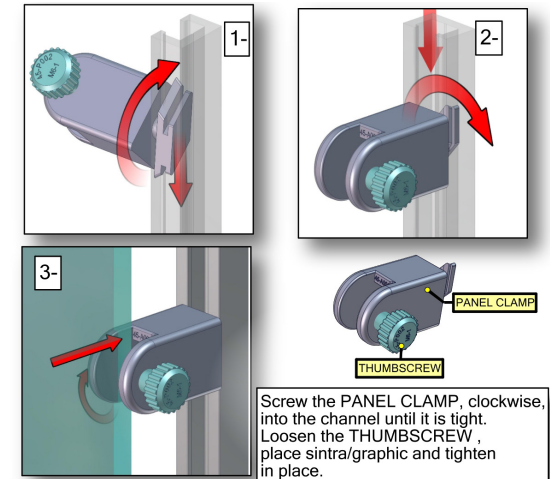
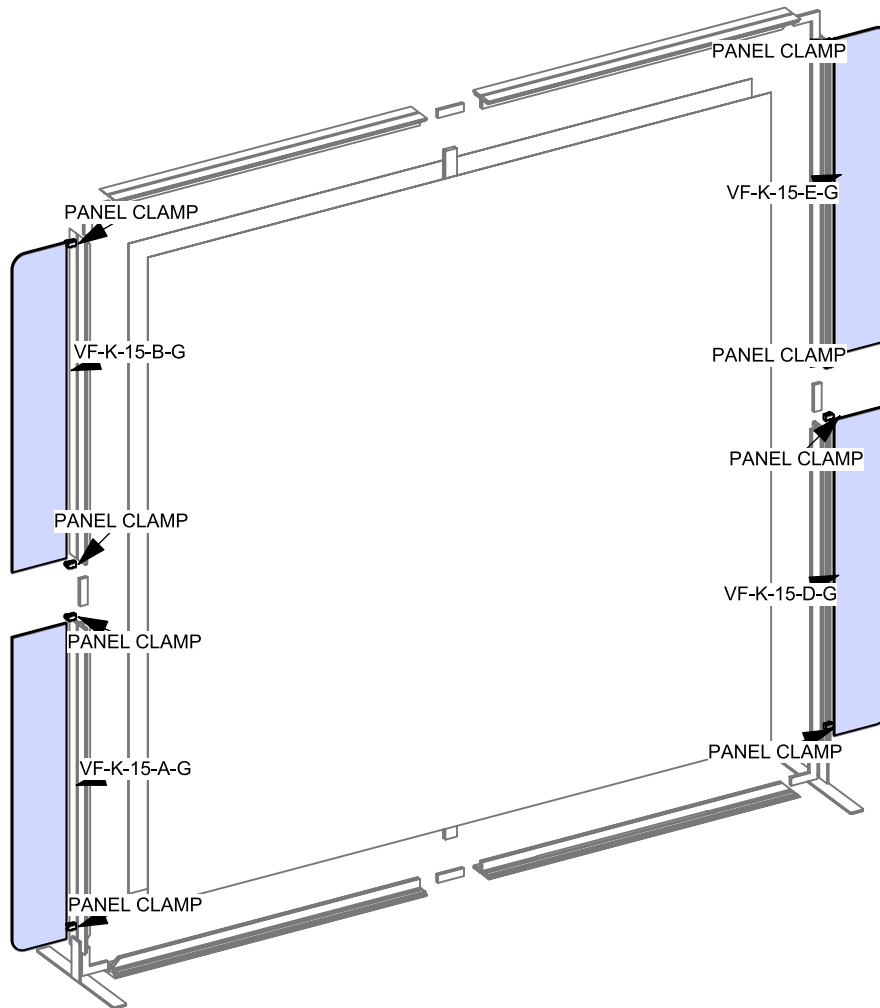

Over-tightening can cause to strip

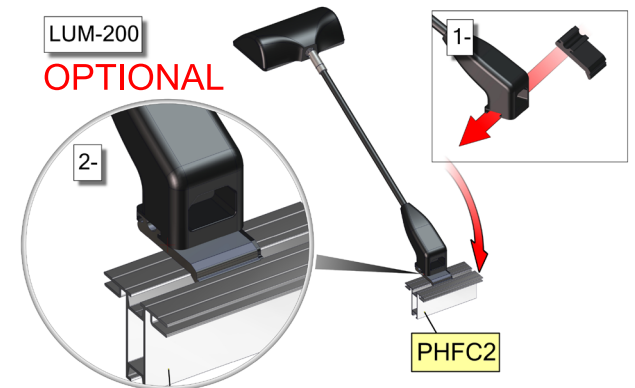

1- Slide light clip onto the LIGHT.
2- Then slide the LIGHT into the channel at an angle and then gently lower down.