

ASSEMBLY INSTRUCTIONS

SMABLCD - DIGITAL SCREEN MASTER SKU: FRMRCKWT66DS

DISPLAYS2GO

Open all boxes first and layout all parts on a level and sturdy floor. Reference parts list to verify that all parts and hardware are present.

Before you begin, read instructions thoroughly prior to assembly. 2 people are required for the installation.

PARTS LIST

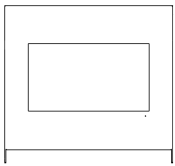

Front Panel X1

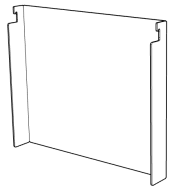

Back Panel X1

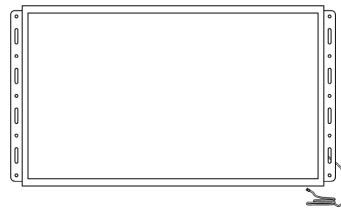

21.5" Screen X1



Screws X6



Spacers X4

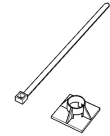

Zip tie X1 and Zip tie holder X1

1. Take Screen and insert into brackets making sure the screen hits the bottom of the brackets shown below.

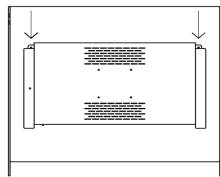
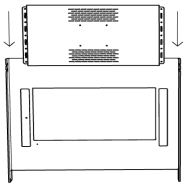

2. Next tie the IR cable to the zip tie holder using the zip tie shown in the images below. Make sure it is secured tightly.

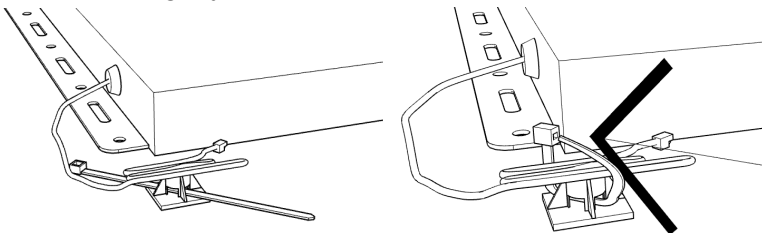

3. Peel bottom of zip tie holder to stick to front panel and place IR over hole like the images below.

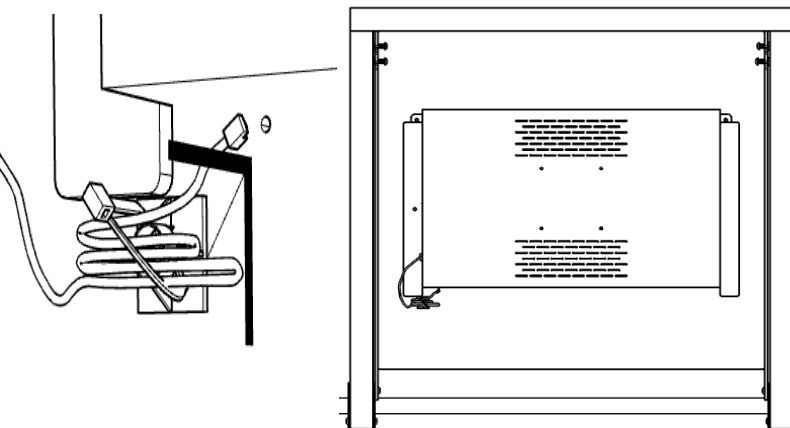

4. Remove screw A and replace with screw and spacer provided in the kit. Repeat steps for screws B, C, and D. Only screw half way.

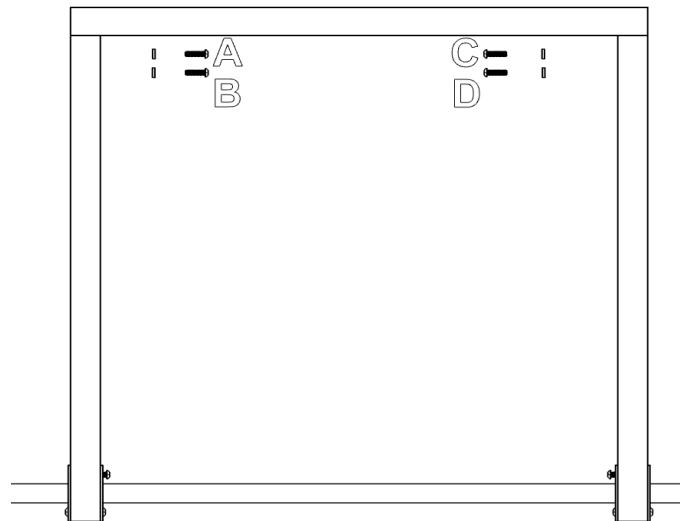

5. Remove screw E and replace with a screw from kit. Repeat step for screw F. Only screw halfway.

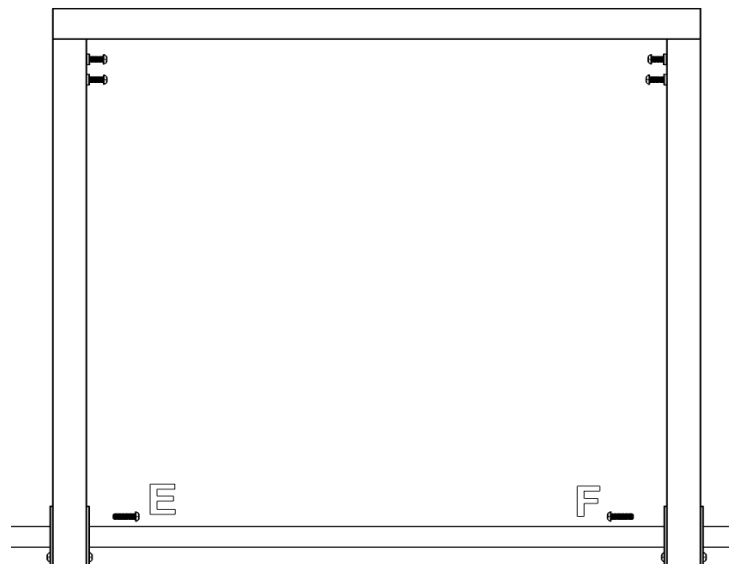

ASSEMBLY INSTRUCTIONS

SMABLCD - DIGITAL SCREEN MASTER SKU: FRMRCKWT66DS

DISPLAYS2GO

6. Slide front panel on the bottom screws first like in the images below. Then push front panel towards the top and hook into place.

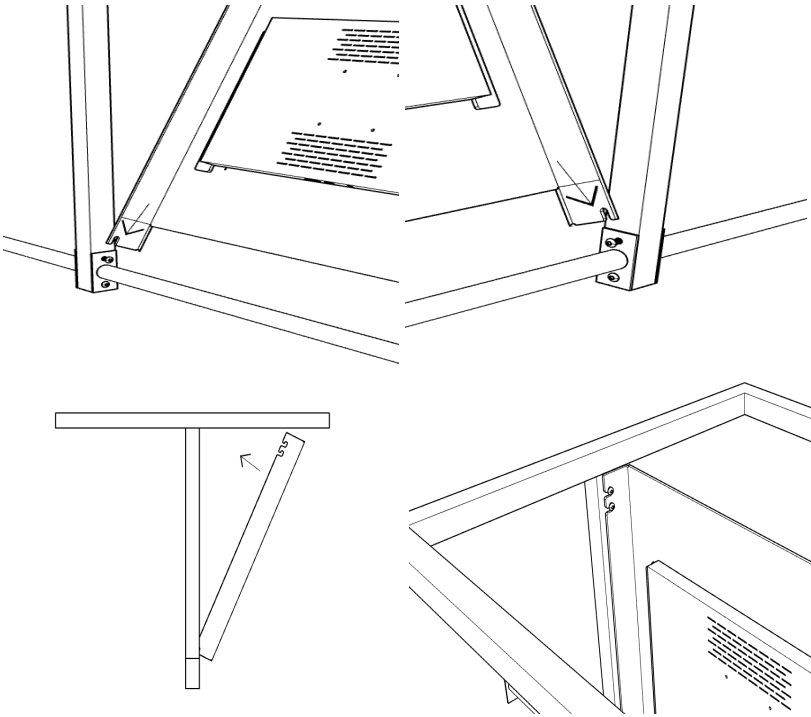

8. Take back panel and hook into top screws as shown in the images below.

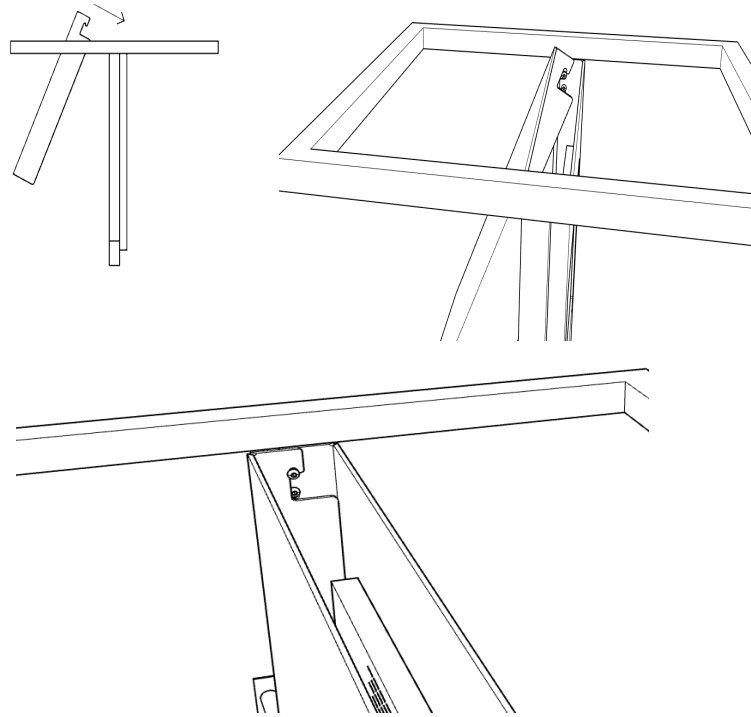

7. Tighten screws B through F. Next loosen screws A and C as shown in the second image below. Screws A and C do not need tightening.

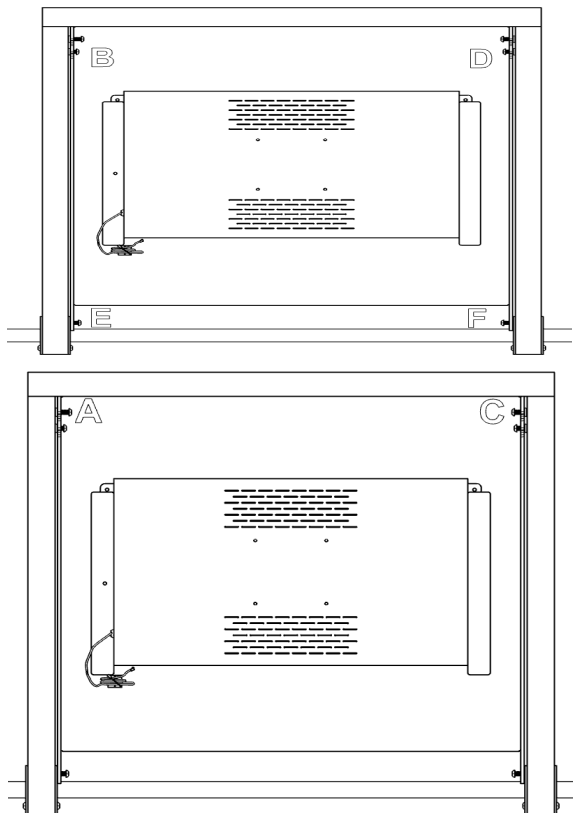

9. Assembled Unit.

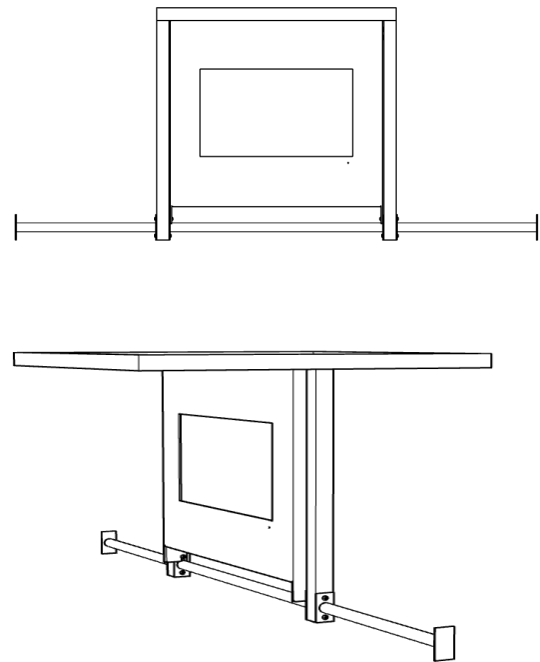

Side note: For cord management use cable hider strips provided with unit to run along the unit. Instructions are provided in box of strips. Best to place one strip at a time.

If you have any questions regarding our products, please visit us at www.displays2go.com or contact D2G Digital product service # 844-221-3393 .