

ASSEMBLY INSTRUCTIONS

FRMRCKWT66DS - METAL CLOTHING RACK WITH DIGITAL SCREEN

A Metal Base 1PC

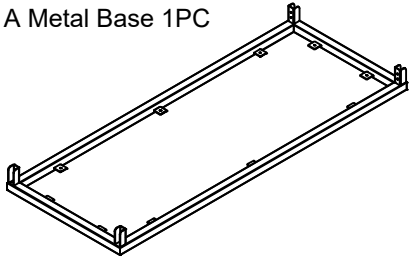

C Side Uprights 4PCS

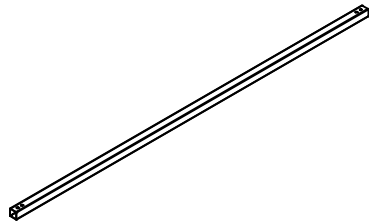

D Top Roof 1PC

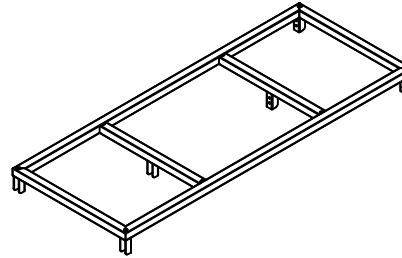

E Hangrail Connector 2PCS



F Middle Hanging Rod 1PCS

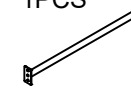

H Levelers 4PCS



B Wooden Shelf 1PC

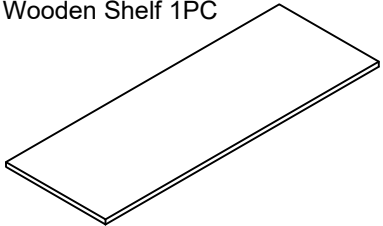

G Side Hanging Rods 2PCS



I White Button Head Screws 28PCS



J Lock Washer 28PCS



K Washer 28PCS



Step 1: Screw the 4 levelers (G) into the pre-drilled holes at the corners of the bottom of the metal base (A)

Step 2: Place the wooden shelf (B) into the metal base (A) so they are resting on the ledges.

Step 3: Place the side uprights (C) onto the channels at the corners of the metal base (A) and fasten using the screws (I) and Washer (K) Lock Washer(J)

Step 4: Place the top roof (D) into the side uprights (C) and fasten using the screws (I) and washers (J). Note: May take multiple people

Step 5: Place the hangrail connectors (E) over the channels in the middle of the top roof (D) and fasten using screws (I) and Washer (K) & Lock Washer(J)

Step 6: Fasten the middle hanging rod (F) between the 2 hangrail connectors (E) using screws (I) and Washer (K) & Lock Washer(J)

Step 7: Fasten side hanging rods (G) to both the left and right side of the hangrail connectors (E) using screws (I) and Washer (K) & Lock Washer(J)

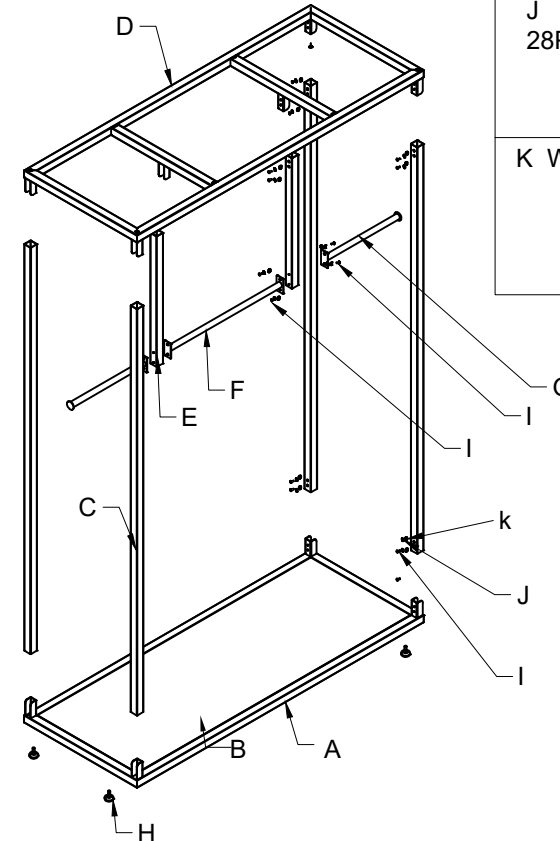
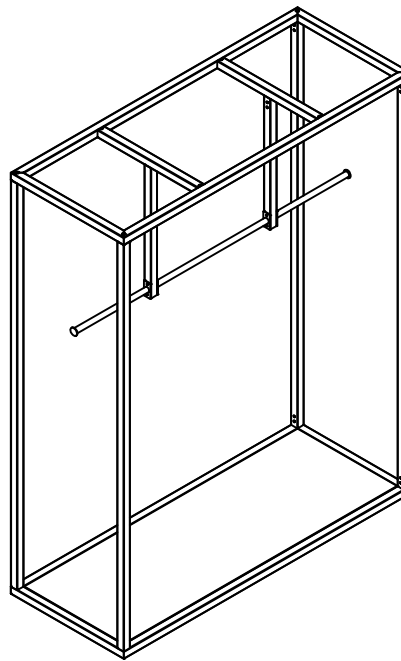

Scan QR code to visit the product page:



NOTE: See *Instructions_SMABLCD.pdf* on how to assemble the LCD screen.