

M2X Series Stand Instructions

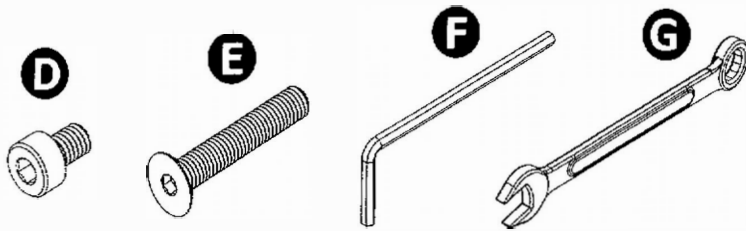

Parts		
	Description	QTY
A.	Post Assembly	1
B.	Base	1
C.	Rotating Bracket	1
D.	M4 Socket Head Screws	2
E.	M5 Flat Head Screws	4
F.	3 mm Allen Wrench	1
G.	13 mm Open Ended Wrench	1
H.	Snap Frame (Attached to C.)	*

*Snap frames vary in size and may not be included if product is purchased with a separate tablet holder. For simplicity, those attachments are not shown on this sheet.

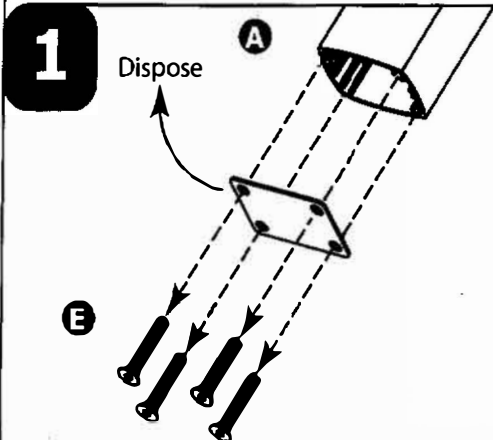

Remove the screws (E) from the bottom of the post (A). Save the screws (E) for step 2. Dispose of the small steel plate.

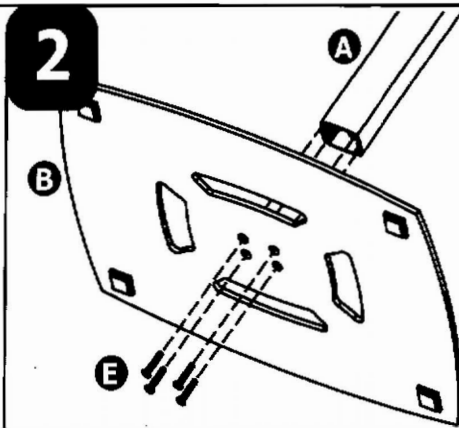

Attach the base to the bottom of the post assembly (A) using the removed flat head screws (E) and allen wrench (F).

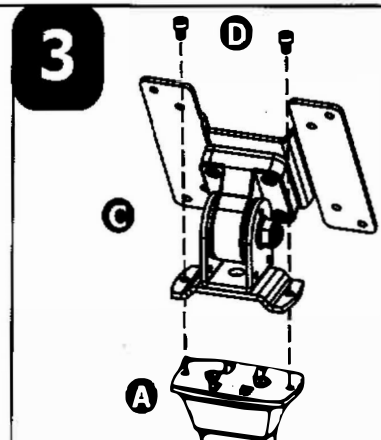

Attach the rotating bracket (C) to the top of the post assembly using the supplied socket head screws (D) and allen wrench (F).

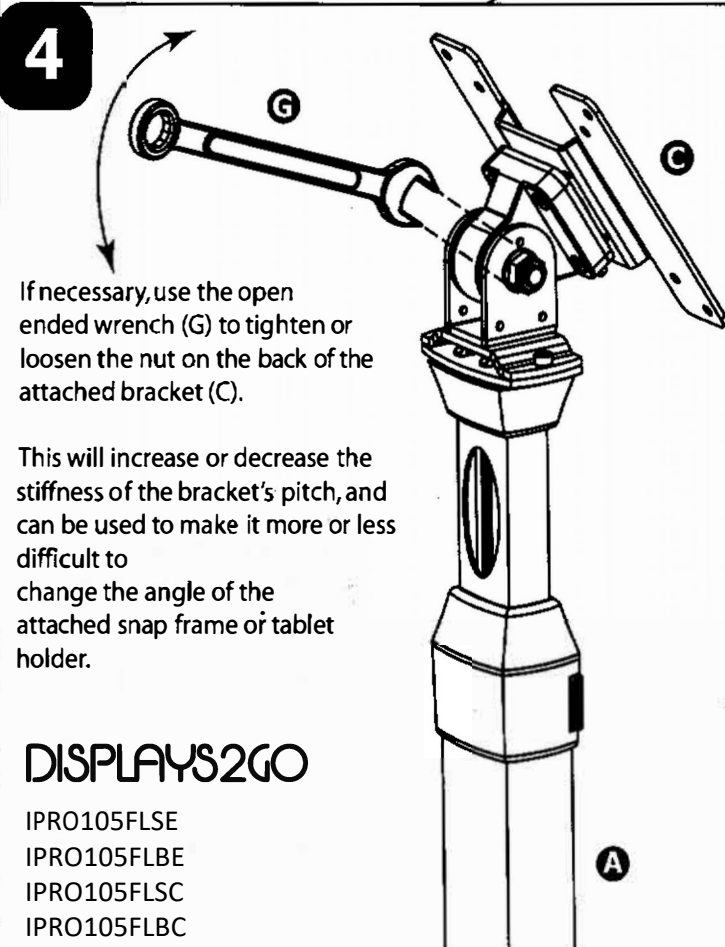

If necessary, use the open ended wrench (G) to tighten or loosen the nut on the back of the attached bracket (C).

This will increase or decrease the stiffness of the bracket's pitch, and can be used to make it more or less difficult to change the angle of the attached snap frame or tablet holder.

DISPLAYS2GO

IPRO105FLSE
IPRO105FLBE
IPRO105FLSC
IPRO105FLBC

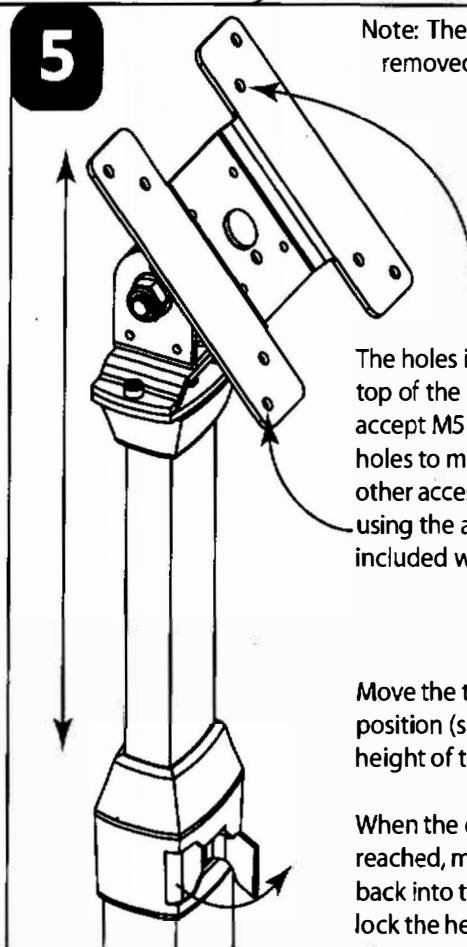

Note: The snap frame has been removed from this picture for simplicity.

The holes in the bracket at the top of the stand are threaded to accept M5 screws. Use these holes to mount tablet holders or other accessories to the stand using the appropriate hardware included with those kits.

Move the thumb tab to the open position (shown) to adjust the height of the stand.

When the desired height is reached, move the thumb tab back into the closed position to lock the height of the stand in