

LECTFLCHW

Assembly Instructions

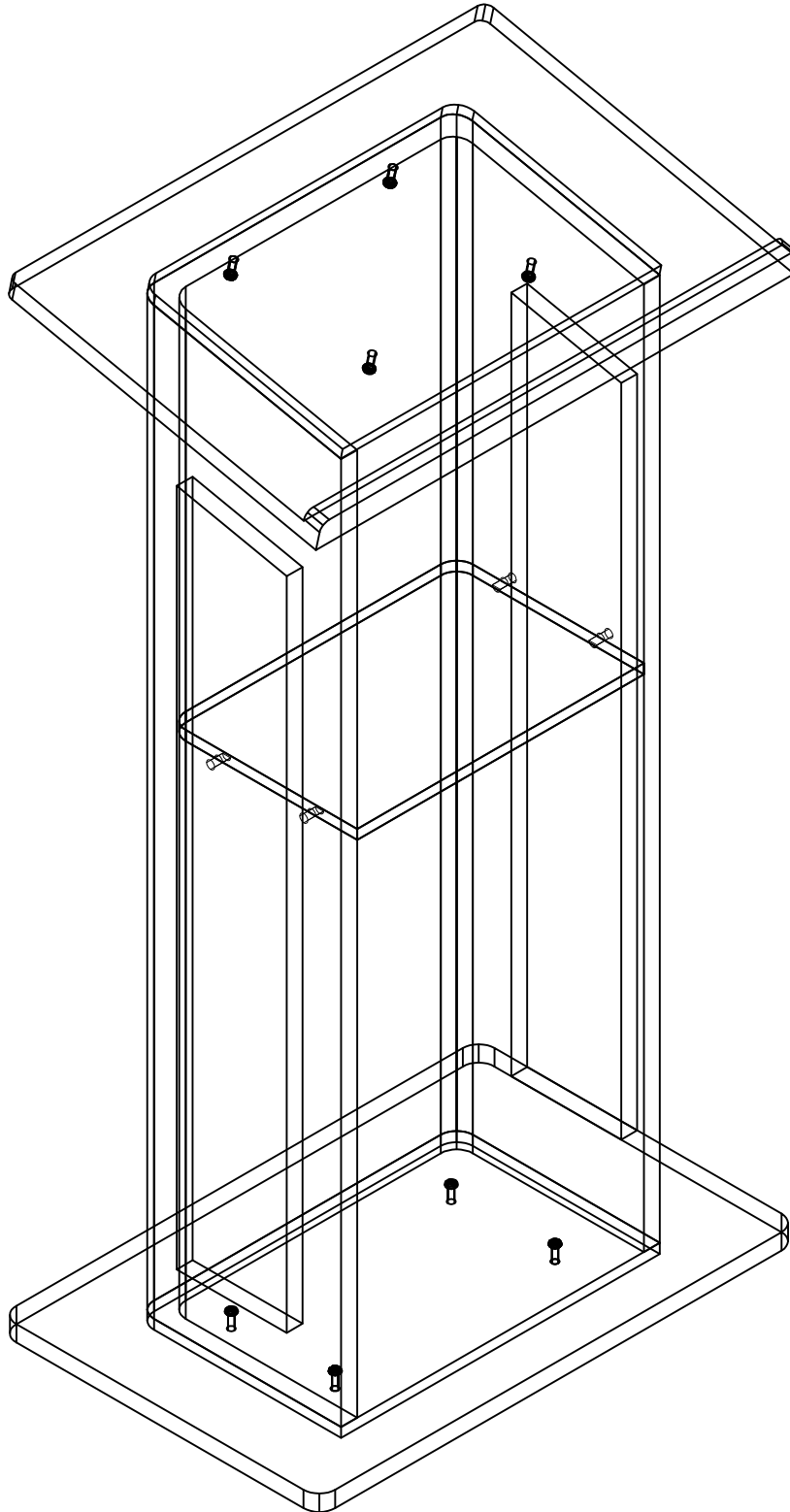

Lectern Parts:

1. Reading Top
2. Base
3. Body
4. Shelf

Hardware:

5. Shelf Supports (4)
6. Flat Head Screws (8)
7. Phillips Head Screwdriver (Not Shown)

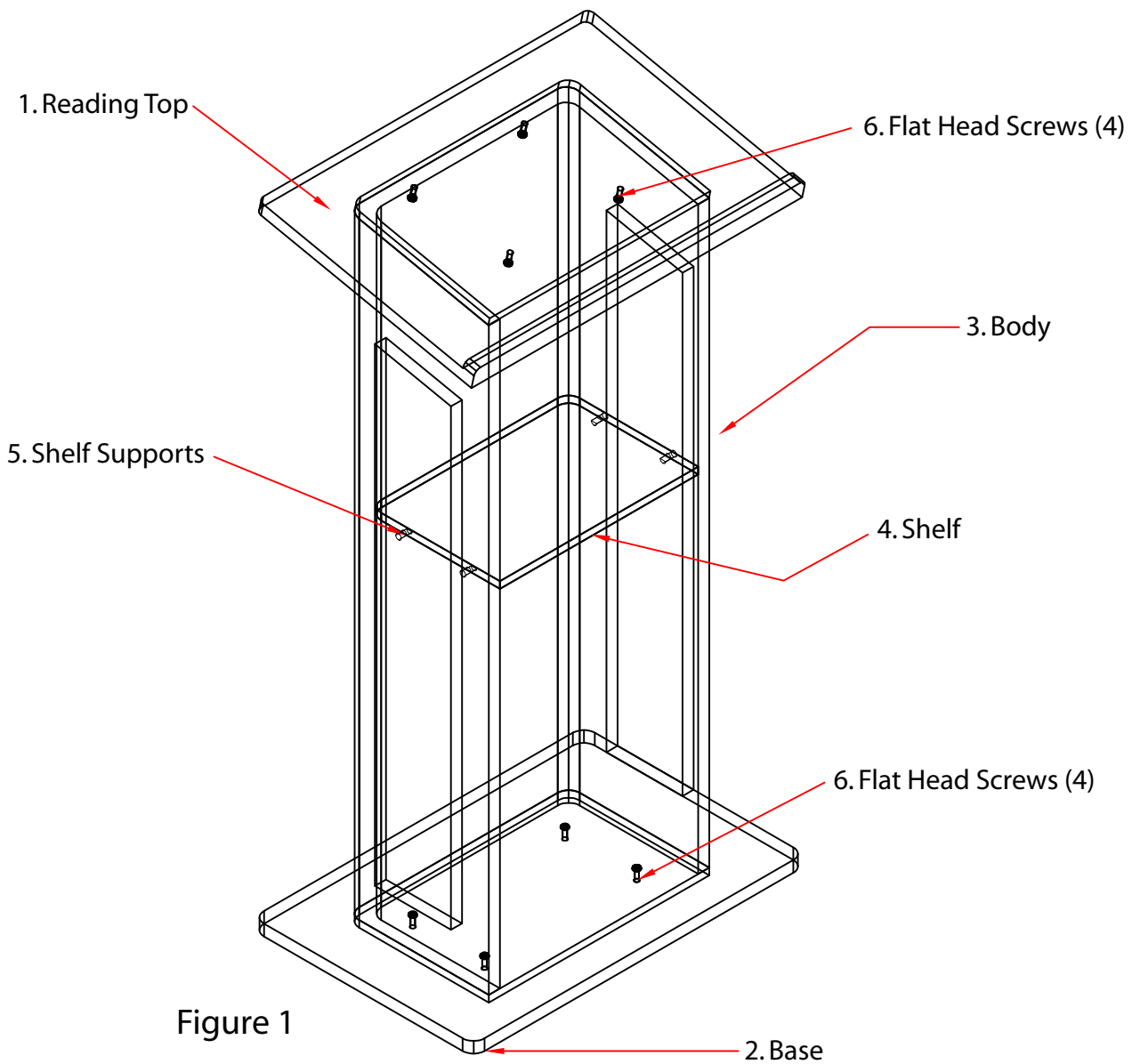

Attaching the Base to the Body

1. Position the **Base** and **Body** on a clean flat surface.
2. Align the pre-drilled holes in the **Body** with the threaded inserts in the **Base**.
3. Using the provided screwdriver, attach the **Body** to the **Base** with (4) **Flat Head Screws** as illustrated in **Figure 2**.

Tip: Do not fully tighten these screws until the unit is otherwise fully assembled.

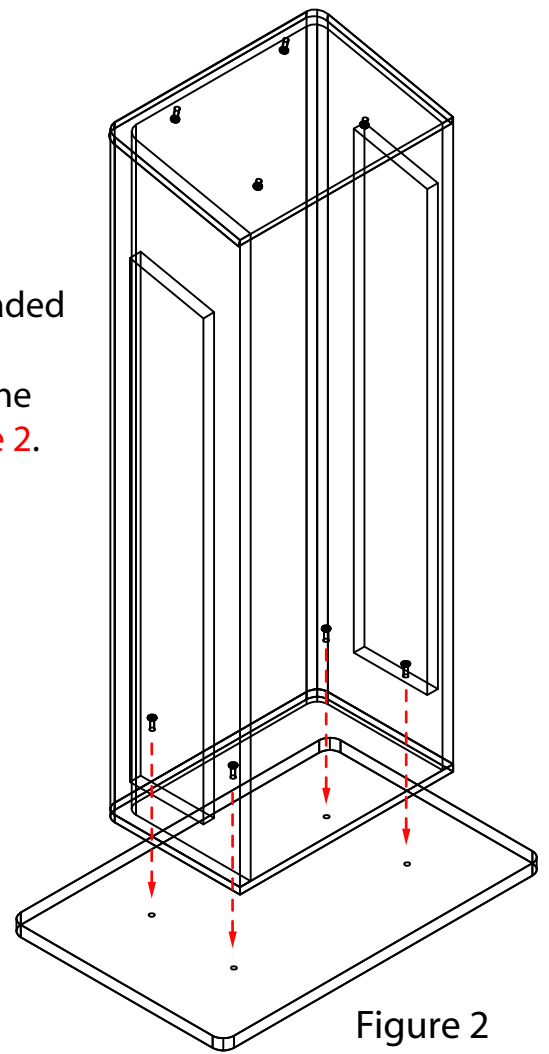

Figure 2

Attaching the Reading Top

1. Position the **Reading Top** over the **Body** as illustrated in **Figure 3**.
2. Align the pre-drilled holes in the **Body** with the threaded inserts in the **Reading Top**.
3. Using the provided screwdriver, attach the **Reading Top** to the **Body** with (4) **Flat Head Screws** as illustrated in **Figure 3**.

Tip: You should now fully tighten all 8 Flat Head Screws.

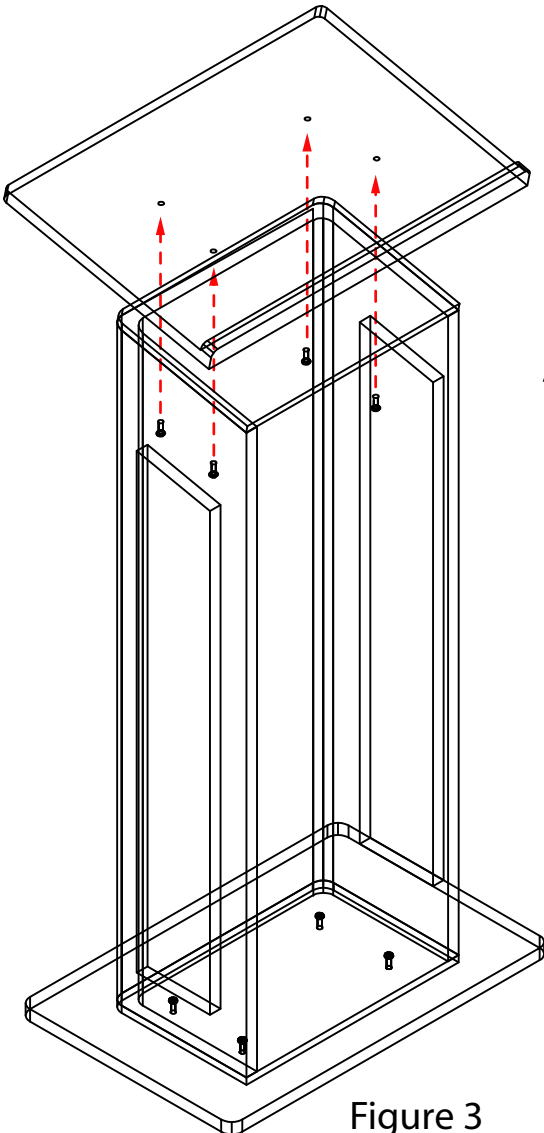
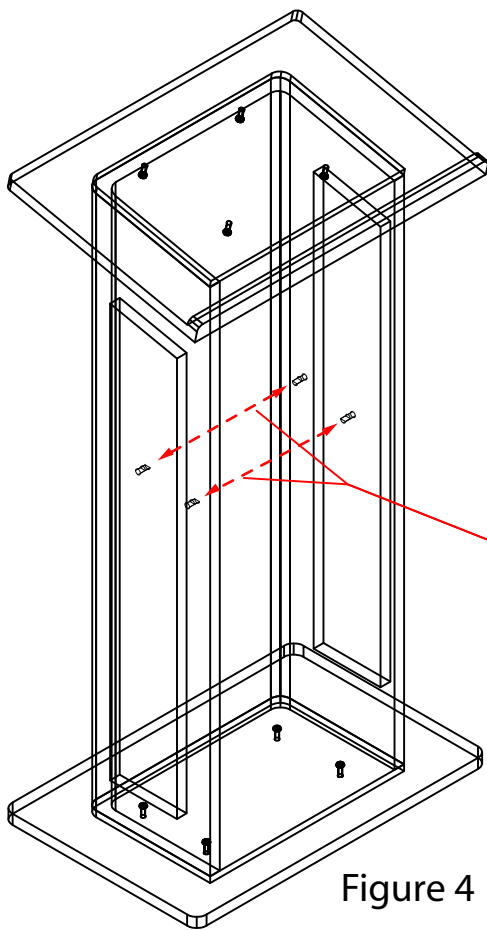

Figure 3

Installing the Optional Shelf

1. Insert 1 **Shelf Support** into each of the four pre-drilled locations identified in **Figure 4**.



Shelf Support installation locations

Figure 4

2. Remove the protective film from the **Shelf**.
3. Place the **Shelf** onto the **Shelf Supports** to complete your LECTFLCHW assembly.

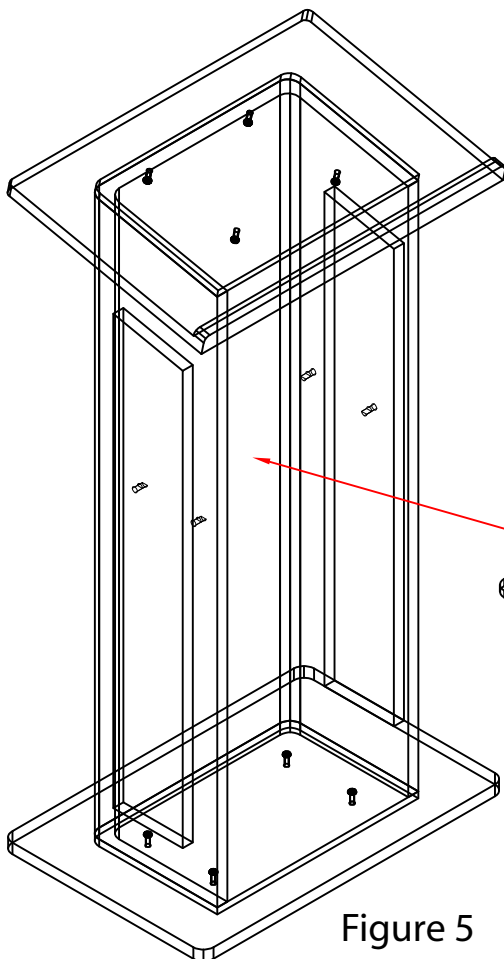

Shelf

Figure 5

