

9900 Series  
Bailey Basic Treatment Table  
Product Manual

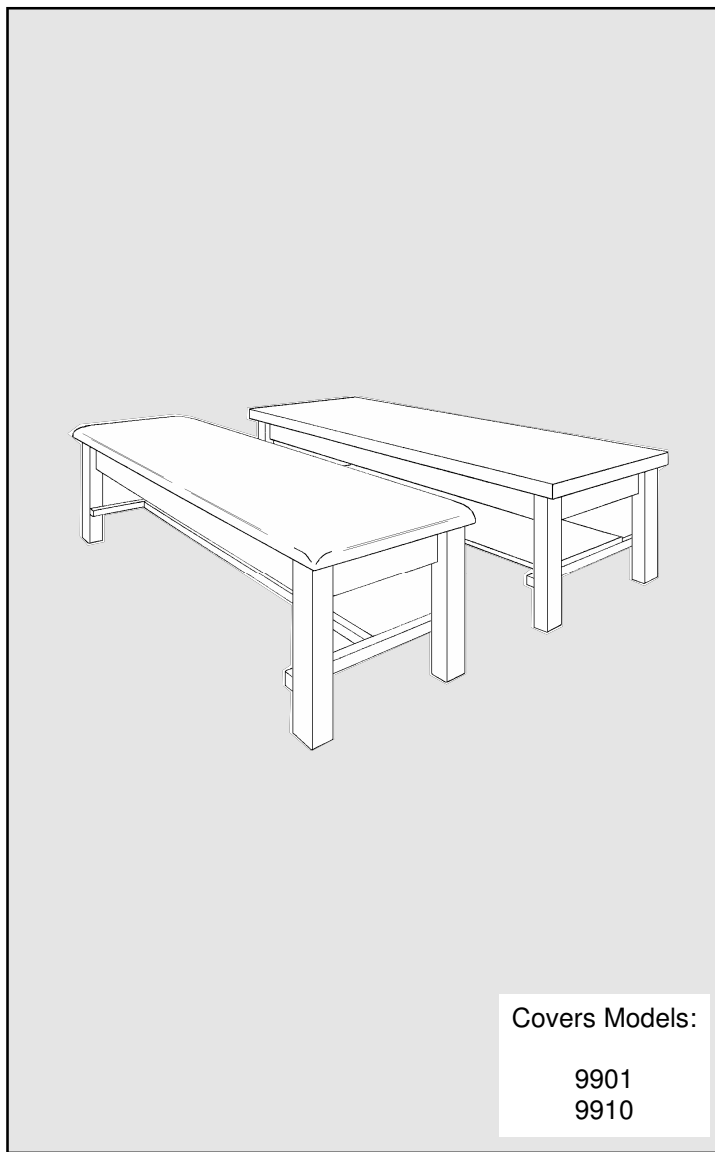

**BAILEY**

B0615

BAILEY MANUFACTURING COMPANY  
800-321-8372 • FAX: 800-224-5390  
Mail: P.O. Box 130, Lodi, OH 44254-0130  
Shipments: 118 Lee St., Lodi, OH 44254  
[www.baileymfg.com](http://www.baileymfg.com)

## ***Important Read This First***

Bailey Manufacturing Company is proud of the reputation we have earned as a leader in the physical, occupational, and sports medicine industry for over 50 years. Our products are made from the highest quality materials and built in the USA by skilled craftsmen.

Prior to shipping, this product was thoroughly inspected to ensure the highest quality standards and your total satisfaction. If you experience any problems, please follow the instructions outlined in the Warranty & Support Section of this manual. Contact either your dealer or Bailey at 1-800-321-8372.

Please take a moment now and record the following information for future reference:

<i>Date of Purchase [delivery date]:</i>
<i>Bailey Dealer:</i>
<i>Packing Slip #:</i>
<i>Serial Number:</i> <i>Date of Manufacture:</i> <i>Model Number:</i>

**Contents:****Pages:****Product Section 4 thru 10**

General Information	4
Parts	4, 5
Assembly	6 - 8
Safety	9
Operation	9
Maintenance & Cleaning	10
Troubleshooting	10
Inspection & Service Logsheet	15

**Warranty & Support Section 11 thru 14**

Warranty Terms	11
Product Support & Assistance	12
Product Registration	13
Damage & Loss In Transit	13
Returns	14

**General Information:**

*Read entire Product Manual before assembling and using this product. If you have any questions regarding the following information, please contact a Bailey Customer Service Representative at 1-800-321-8372.*

**Features & Specifications, Models 9901 & 9910:**

- Black vinyl upholstery meets flammability specifications of Boston Fire Code BFD IX-1 and California Bulletin 177(e).
- Thick [**Model 9901, 1"**; **Model 9910, 2"**] anti-bacterial foam padding for patient comfort.
- Convenient 30" total fixed height.
- Rigid "H" Brace for added stability and Plain Shelf [**Model 9910 only**] for storage.
- Maximum static load capacity of 300 lb. / 136 Kg.

**Options & Accessories, Models 9901 & 9910:**

- Factory installed options [Color choices, Nose Slot, Stirrups, Drawers, etc.] are **NOT** available on these models.
- Models 47 & 48 Paper Cutters, Model 46 Paper Holder, and Model 35 Adjustable Arm Board are available.

**Parts:**

Your new Bailey Basic Treatment Table is shipped "knocked down", with all hardware and parts needed for final assembly. Inspect the unit carefully, immediately upon removal from packaging, to ensure that the unit is in good condition and all materials are present before starting assembly.

*Note: Bailey Manufacturing Company waives any responsibility for concealed freight damage not reported within five (5) days of receiving shipment.*

Refer to Product Warranty and Support Section of this Manual for more information.

**Figure 1**  
**Treatment Table Parts Location**

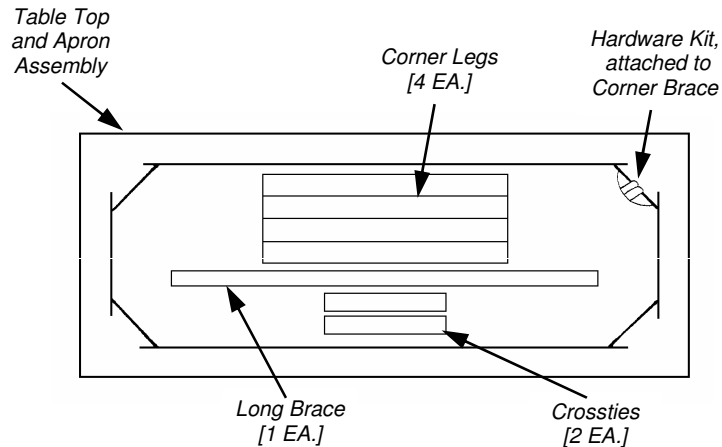

***Parts [cont'd]:***

The following Hardware Kit is in a poly bag:

- (4) EA. # 2401 Lag Bolt, 3/8 x 4"
- (4) EA. # 3597 Lockwasher, 3/8
- (4) EA. # 3610 SAE Flatwasher, 3/8
- (8) EA. # 3220 2" x #10 Flathead Wood Screws

The Model 9910 has the following additional hardware:

- (3) EA. # 3230 2 1/2" x #10 Flathead Wood Screws

The following parts are fastened to the back of the Table:

- (4) EA. Corner Legs
- (2) EA. Crossties
- (1) EA. Long Brace

The Model 9910 has the Plain Shelf wrapped in cardboard alongside the Table Top and Apron Assembly. **Be careful to locate this shelf before discarding any cardboard!**

***Note: Any Angle Brackets and Tapping Screws that are used to retain parts for shipment are not needed for***

**Assembly:**

The following minimum tools are required:

- 9/16" wrench
- Flat Blade screwdriver

Any of these additional tools will make assembly easier:

- 9/16" socket and drive ratchet
- Portable electric drill with Flat Blade drive bit

**Leg & H-Brace Assembly [Refer to Figures 2 & 3, opposite page]:**

Place the Table Top and Apron Assembly upside down on a smooth, clean surface. Place one Corner Leg in each corner at the gap in the Apron, with the notch and Lag Bolt starter hole facing inside towards the Corner Brace [Figure 2]. Match each Leg to a corner so that each leg has one Crosstie starter hole facing inward along the length of the table [Figure 3].

Attach each of the four (4) Corner Legs using one (1) Lag Bolt, Lockwasher and Flatwasher [Figure 2]. **Do not tighten Lag Bolts at this time! Legs must be loose enough to move.**

Attach each of the two (2) Crossties to a pair of Legs [Crosstie notches face inward toward each other, Figure 3] at each end using one (1) 2" x #10 Flathead Wood Screw per Leg. The screws go through the predrilled holes in Crossties and into predrilled starter hole in Legs. **Do not tighten screws at this time! Crossties must be loose enough to move.**

Attach Long Brace between Crossties, using two (2) 2" x #10 Flathead Wood Screws through each Crosstie and into starter holes in Long Brace. **Do not tighten screws at this time! Note, Model 9910 only: there are three predrilled holes in the Long Brace which must have the countersunk side facing toward the bottom of the table.**

**Figure 2**  
**Treatment Table Corner Leg Assembly**

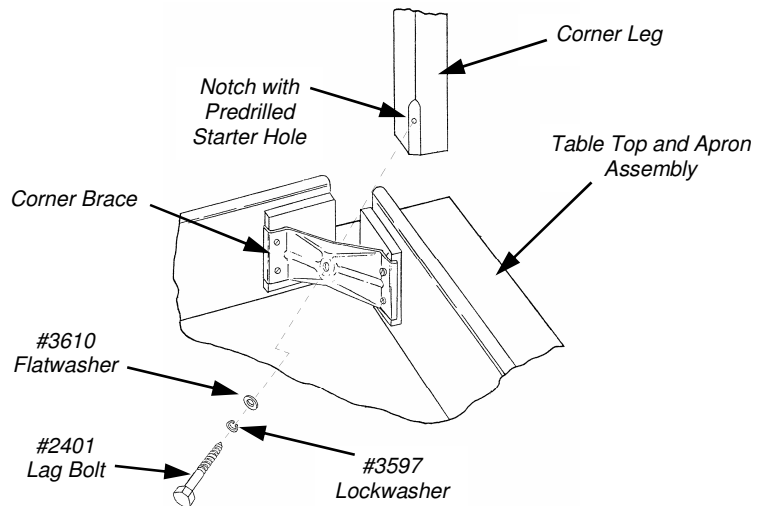

**Figure 3**  
**Treatment Table H-Brace Assembly**

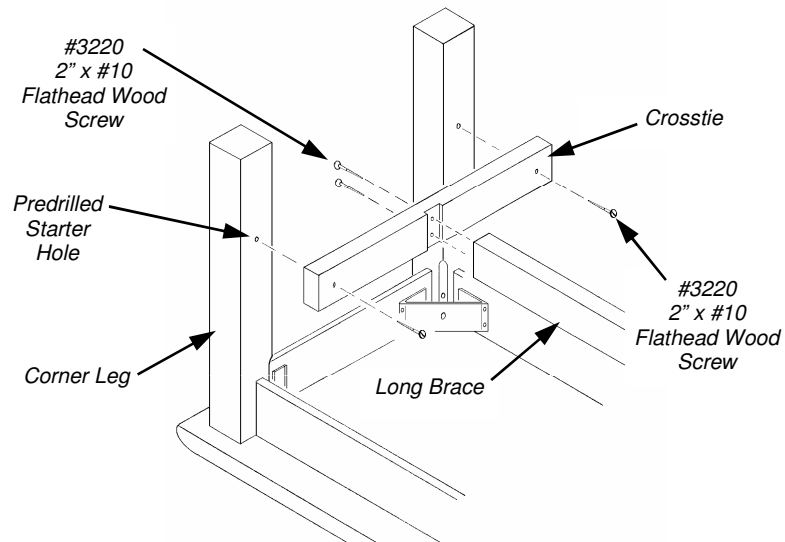

***H-Brace Assembly [Cont. 'd]:***

Attach Plain Shelf [**Model 9910 only, Figure 4, opposite page**] to Long Brace using three (3) 2 1/2" x #10 Flathead Wood Screws. The Shelf has three (3) predrilled starter holes in one unfinished side. Align these with the matching holes in the Long Brace and install the Wood Screws. Tighten these three Screws from the center outward, until the shelf is flush with the Long Brace and the Screws are flush or slightly below the wood surface.

Finish tightening all fasteners in the following sequence:

- Shelf [Model 9910 only], from center screw outward.
- Crosstie to Long Brace screws.
- Corner Leg to Corner Brace Lag Bolts, gradually and in sequence around the table until Lockwashers flatten out and Legs are drawn securely into the Apron gap.
- Crosstie to Corner Leg screws.

The Flathead Wood Screws are tight when mating parts fit together flush and screw heads are flush or slightly below the wood surface.

*Note: Tightening each Corner Leg fully before starting the next one, or tightening screws out of recommended sequence may result in a warped or distorted table. If this occurs, loosen all fasteners until table flattens out, and carefully retighten all fasteners in sequence.*

Turn Treatment Table upright and place in location to be used. The floor should be as flat and level as possible.

Check all fasteners and components for proper tightness and fit. Your Treatment Table is now ready to use.



**Figure 4**  
**Plain Shelf Assembly [Model 9910 only]**

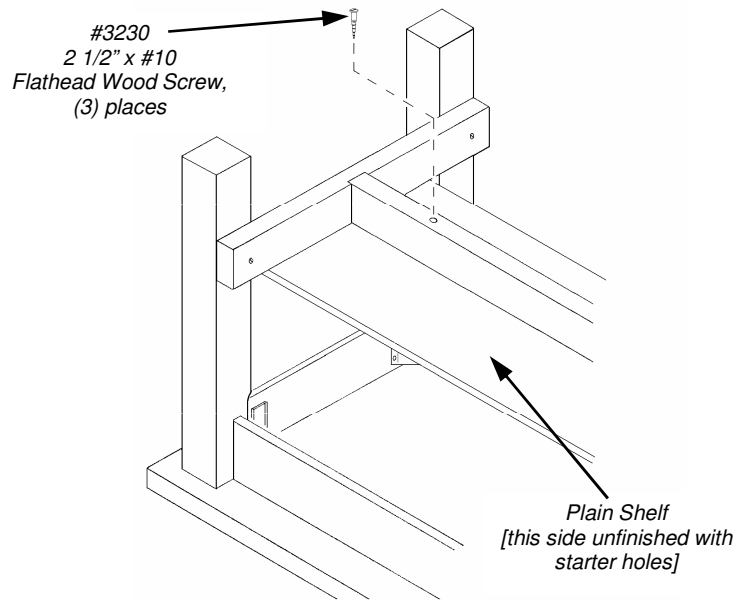

**Safety:**

Be safe! Never attempt to assemble or move a table yourself; always seek assistance. Avoid placing the table against walls or in contact with other equipment in order to eliminate pinch points. Always observe Table Static Load Ratings as stated on page 4.

**Operation:**

Avoid storing items on the H-Brace without a storage Shelf. When using the table alongside a wheelchair or with a prosthesis, take care to minimize contact with the upholstery corners and sides. This will avoid punctures and abrasion in the upholstery.

***Maintenance & Cleaning:***

Regularly inspect components for wear and proper adjustment. Should the unit need attention, remove from service until the unit is returned to its original condition. A convenient Inspection and Service Logsheet is provided on page 15 for recordkeeping.

To help keep your table in good condition, clean as required using **abrasive free** and **solvent free** products. Test any cleaner or disinfectant on a small, inconspicuous location before using. Discontinue use if surface softens, discolors, or loses gloss.

*Never use any cleaners or disinfectants containing harsh solvents on product surfaces. Check their Material Safety Data Sheet and consult the manufacturer with any questions. Some chemicals will severely shorten the life of your vinyl upholstery and lacquer coated finishes.*

*For light soiling, upholstery manufacturers recommend liquid dish soap and water, or liquid cleanser and water applied sparingly with a soft bristle brush. For difficult stains or disinfection, use a solution of 10% household bleach [sodium hypochlorite] and 90% water applied sparingly with a soft white cloth. Rinse with water dampened cloth to remove any remaining soap, cleanser or bleach solution.*

***Troubleshooting:***

Your new Bailey Basic Treatment Table will provide years of reliable service. In the event the Table does not function correctly, inspect all components for tightness and proper condition.

For detailed information or component replacement, contact Bailey Customer Service at the number on this page. **Have your date of purchase and Bailey Dealer information handy for faster service.**

***Two Year Limited Warranty:***

Bailey Manufacturing Company warrants its Bailey Basic products [Model 9900 Series] to be free of defects in materials, workmanship, or design under normal use and service conditions for two years after the date of original purchase. Resale products and components manufactured by others will carry the warranty of the manufacturer. If the product and/or equipment should become defective within the designated warranty period, Bailey Manufacturing Company will repair or replace it (at our option) free of charge, including return transportation to you, provided you deliver the equipment or product prepaid to Bailey Manufacturing Company at 118 Lee Street, Lodi, Ohio 44254. Please receive "authorization" before returning product to the factory, as Bailey Manufacturing Company will not accept collect shipments. Bailey Manufacturing Company reserves the right to repair or replace component parts without return of the entire unit.

This warranty does not include damage resulting from accident, abuse, or misuse of the product and expressly excludes normal wearing of parts or defect caused by transportation, accident, fire, flood, alteration, or negligence.

Bailey's warranty liability is limited to that stated above; other than the warranty stated above, there are no warranties expressed or implied. Bailey will have no responsibility for consequential or incidental damages.

***Product Support:***

Bailey Manufacturing Company is totally committed to producing the finest quality physical, occupational, and sports medicine products. Our goal is your total satisfaction. If you experience any problems, please feel free to contact a Bailey Customer Service Representative at 1-800-321-8372 between the hours of 8:30 AM and 4:30 PM Eastern Time weekdays.

The following information is provided to help ensure that your experience with Bailey is a positive one. Please read this information carefully before you unpack or begin assembly.

***If You Need Assistance:***

To provide the best possible service to our customers and dealers, warranty claims should be made directly to Bailey. Since Bailey is in the best position to solve the customer's problem, it will speed up the process and help ensure total customer satisfaction. Should you encounter any problem with our products or services, please contact a Bailey Customer Service Representative at 1-800-321-8372 between the hours of 8:30 AM and 4:30 PM Eastern Time, weekdays. Please have the date of purchase and Bailey dealer information recorded inside the front cover of this manual, or a copy of your packing list available to help our customer service representative provide you with the fastest service. In most cases, you will also want to notify your dealer to enable them to provide any further assistance.

***Registration:***

Product registration will be accomplished through the use of the enclosed Product Registration Form. *Please take time to complete this Form and return it to Bailey.* We also ask that you answer a few simple questions concerning our products and services. Our goal is your total satisfaction, and this information will be used to improve our products and services for you...the customer. *Please take a moment to record your purchase inside the front cover of this manual. Note the date and the name of your Bailey dealer.*

***Damage or Loss in Transit:***

All of our equipment is thoroughly inspected and carefully packed before leaving our plant. It is receipted for by the carrier as having been shipped in good condition. Any loss or damage which occurs to the equipment in route will be solely through negligence of the carrier and all claims must be filed directly with the carrier. Important; If a shipment is delivered to you in a visibly damaged condition or in a quantity that is less than is enumerated on the Bill of Lading or delivery receipt, insist on a notation of this damage or shortage by the delivering carrier's agent on the delivery receipt or freight bill. When a shipment has been delivered to you in apparent good condition, but upon opening the containers or crate, damage is discovered, notify the delivering carrier immediately upon discovery. This notification must be made within 5 days of receipt of the shipment. Insist upon an inspection and inspection report. You must retain all packaging, including the carton or crate in which the damaged item was shipped, until inspection has been made. All claims must be made by you, the consignee, directly to the carrier or its agents.

***Returns:***

Merchandise to be returned **must** have proper authorization. Please contact your dealer for assistance with this procedure. A reference (return authorization or RA) number is to be clearly marked on all cartons and correspondence. Freight charges are to be prepaid, as collect shipments are not accepted. Items must be in the original packaging and returned within 30 days of the invoice date. Returns that are **not** the result of a warranty claim are subject to a restocking fee of 20% to cover inspection and handling. Any damage due to use, mishandling, or improper packing of the return will be noted and deducted from the credit issued. Special order items may not be returned for credit. Bailey Customer Service Representatives will complete a "Returned Merchandise Information" form to clearly identify all information concerning the returned merchandise.

***Specifications:***

Due to continuous improvements in design, materials, and construction techniques, specifications in the Bailey catalog are subject to change without notice. In all cases, the equipment shipped will be of equal or superior quality. Bailey Manufacturing Company also reserves the right to discontinue the manufacture of any product at such time as we consider necessary.

***Customer Service:***

When service is required, it is nearly impossible to place a value on it. For that reason we have an extremely competent Customer Service Department available to assist you with answers to your questions or recommendations in your planning process. In the unlikely event that a product may be in need of repair, our staff will assist with prompt identification of the required replacement part. Have the date of purchase and the name of your Bailey dealer handy for reference. Please contact us at 1-800-321-8372 between the hours of 8:30 AM and 4:30 PM Eastern Time weekdays for assistance.



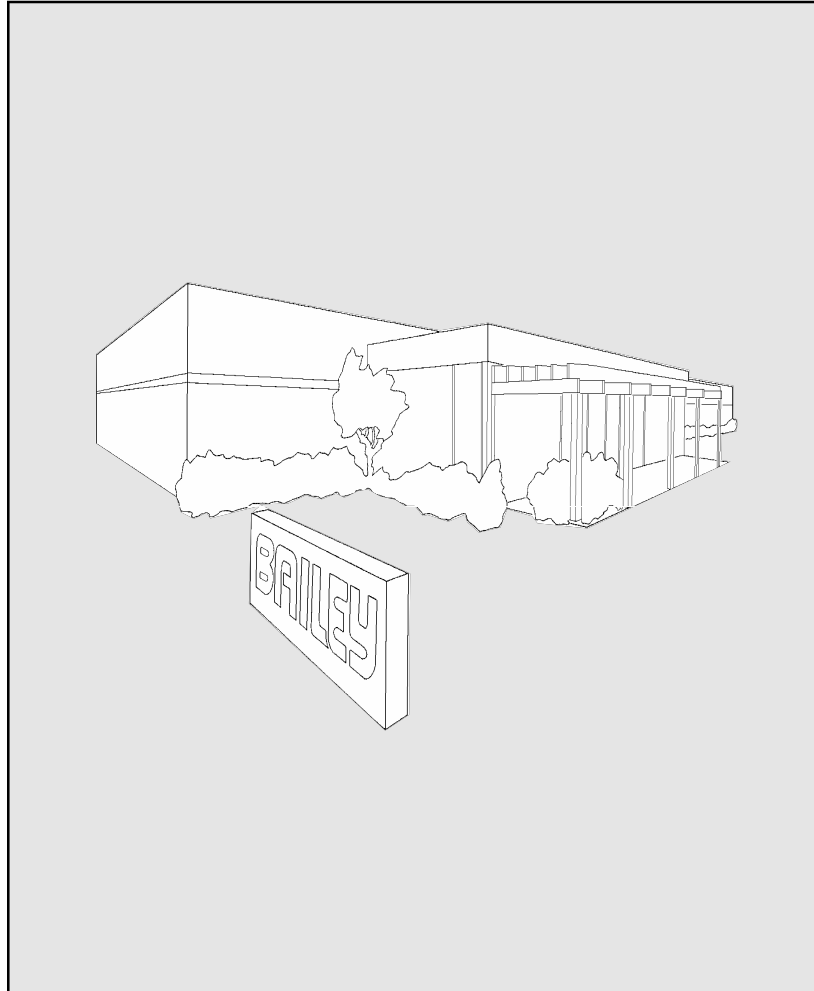

# BAILEY

BAILEY MANUFACTURING COMPANY  
800-321-8372 • FAX: 800-224-5390  
Mail: P.O. Box 130, Lodi, OH 44254-0130  
Shipments: 118 Lee St., Lodi, OH 44254  
[www.baileymfg.com](http://www.baileymfg.com)