

BAILEY

Model 450, 454 & 9920 Stationary 4 x 7 Mat Table Assembly Instructions

Mat Table Corner Leg Assembly

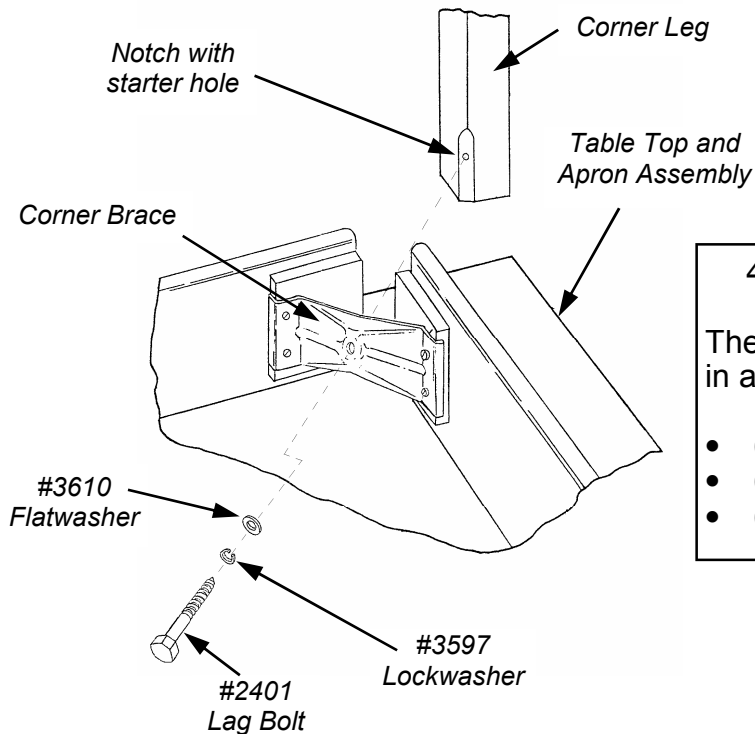

450-454-9920 HARDWARE LIST:

The following Hardware Kit is packaged in a poly bag with the Table:

- (4) EA. # 2401 Lag Bolt, 3/8 x 4"
- (4) EA. # 3597 Lockwasher, 3/8
- (4) EA. #3610 SAE Flatwasher, 3/8

Step 1

Place the Table Top and Apron Assembly upside down on a smooth, clean surface. Place one Corner Leg in each corner at the gap in the Apron, with the notch and starter hole facing inside towards the Corner Brace.

Attach each of the four (4) Corner Legs using one (1) Lag Bolt, Lockwasher and Flatwasher as shown in Figure 2. Tighten each Lag Bolt gradually and in sequence between the four corners until the Lockwasher flattens out and the Corner Leg is drawn securely into the Apron gap.

Note: tightening each corner fully before starting the next one may result in a warped or distorted Table. If this occurs, loosen all Lag Bolts until Table flattens out, and gradually retighten Lag Bolts in sequence.

Step 2

Turn table right side up, and check for tightness and proper assembly before use. If table needs to be leveled due to uneven flooring, use nail-on Glides on leg bottoms where required.