

Orbus Sirius truss kit

DISPLAYS2GO

OESIKIT

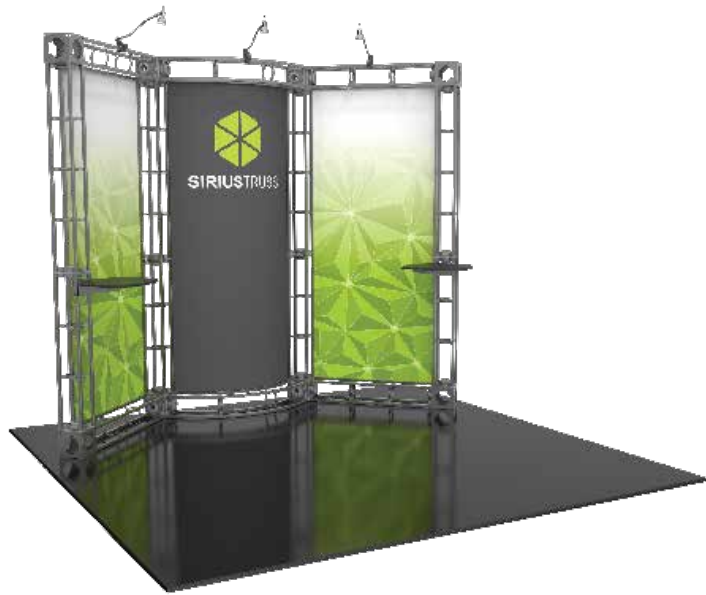

- Kit includes:

- 8 x 6-way junction boxes
- 8 x 36" straight truss lengths
- 4 x 46" straight truss lengths
- 2 x 90° curved truss lengths
- 1 x full set of quicklock connectors
- 2 x adjustable tabletops
- 3 x 50 watt spotlights

Graphics:

Refer to related graphic template for specific information on sizes and bleeds.

We are continually improving and modifying our product range and reserve the right to vary the specifications without prior notice. All dimensions and weights quoted are approximate and we accept no responsibility for variance. E&OE. See Graphic Templates for graphic bleed specifications.

SIRIUS PIECE COUNT:

 OR-J-3
8

 OR-J-DBL
0

 OR-24-2
0

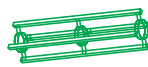
 OR-30-2
0

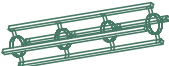
 OR-36-2
8

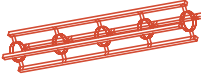
 OR-46-2
4

 OR-45-CV-3
0

 OR-90-CV-2
2

 OR-B90
0

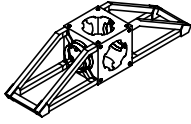
 OR-B90A
0

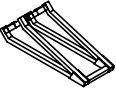
 OR-B45
0

 OR-TOOL-B
1

 OR-QL-T2J
21

 OR-QL-T2T
5

 OR-UC-QL
0

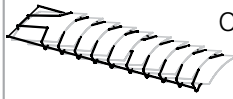
 OR-STG
0

 OR-LCD1-B
0

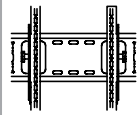
 OR-LCD2-B
0

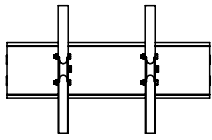
 OR-LCD3-B
0

 SPOTLIGHT
3

 OR-TBL
2

 OR-TBL2-L
0

 OR-TBL2-R
0

 OR-IS-24 0

 OR-IS-36 0

 OR-IS-46 0

 OR-IS-48 0

 OR-CIS-90
0

 OR-SE-IS-90
0

 OR-CIS-45
0

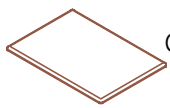
 OR-ATL-CNTR
0

SIRIUS TABLETOP ACCESSORY PIECE COUNT:

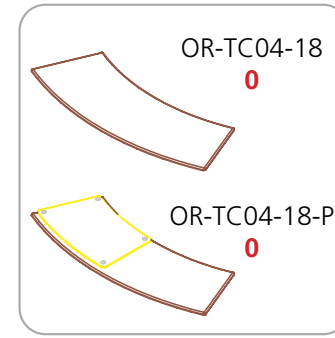
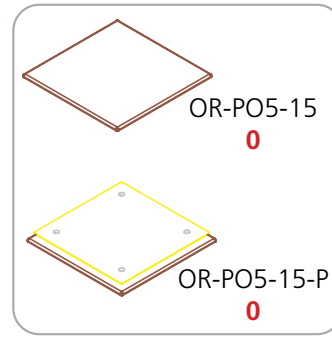
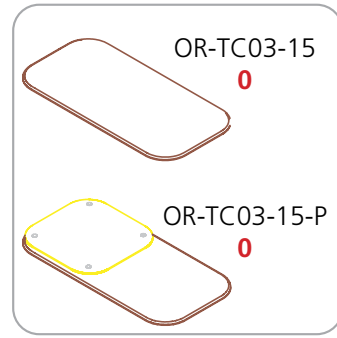
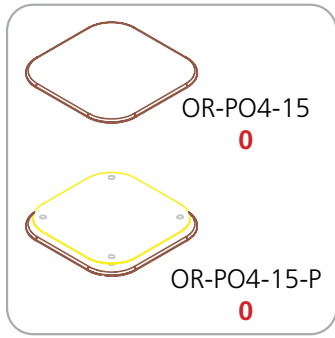
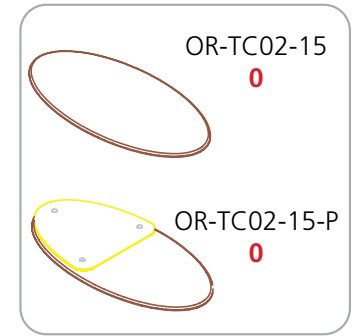
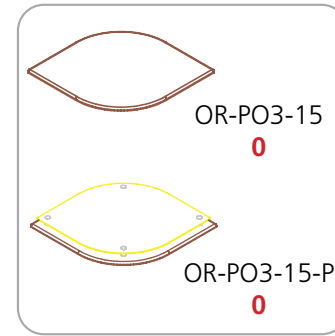
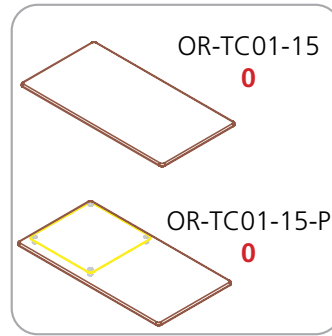
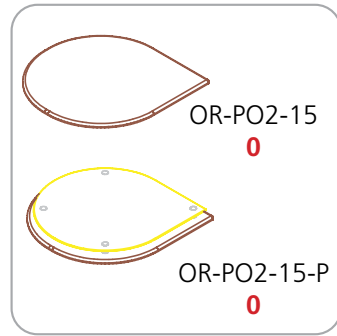
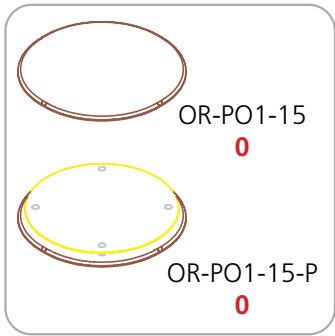

SIRIUS CASE COUNT:

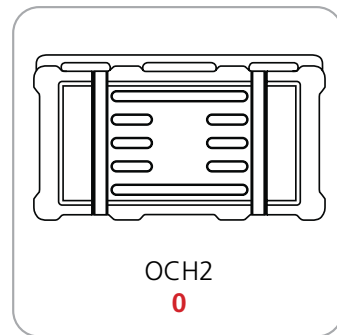
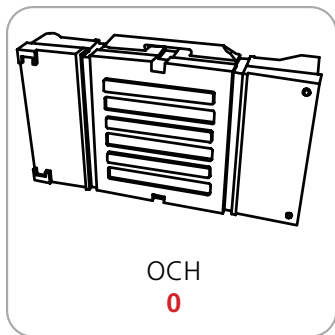
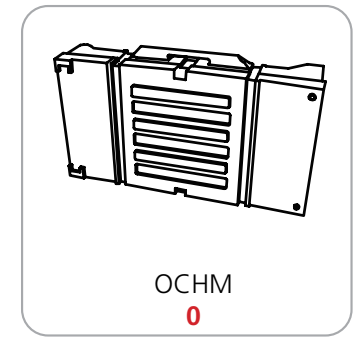
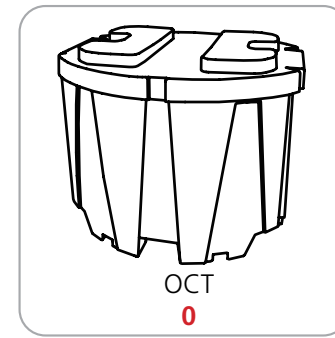
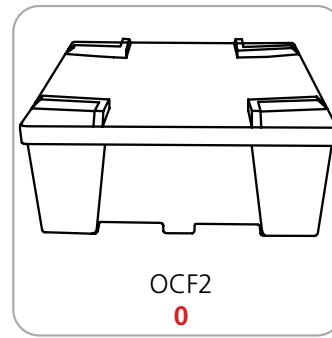
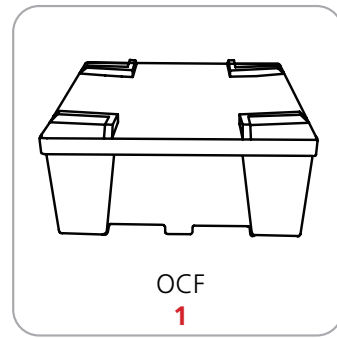
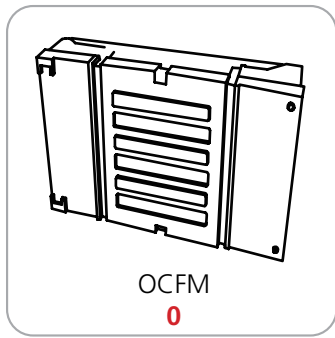

SIRIUS GRAPHIC SPECS:

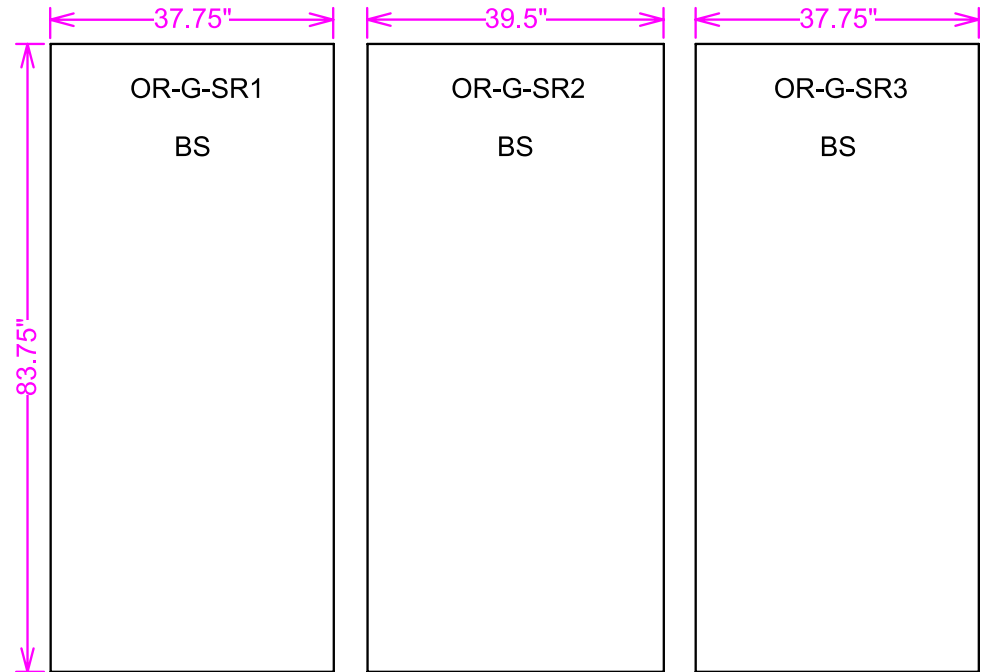
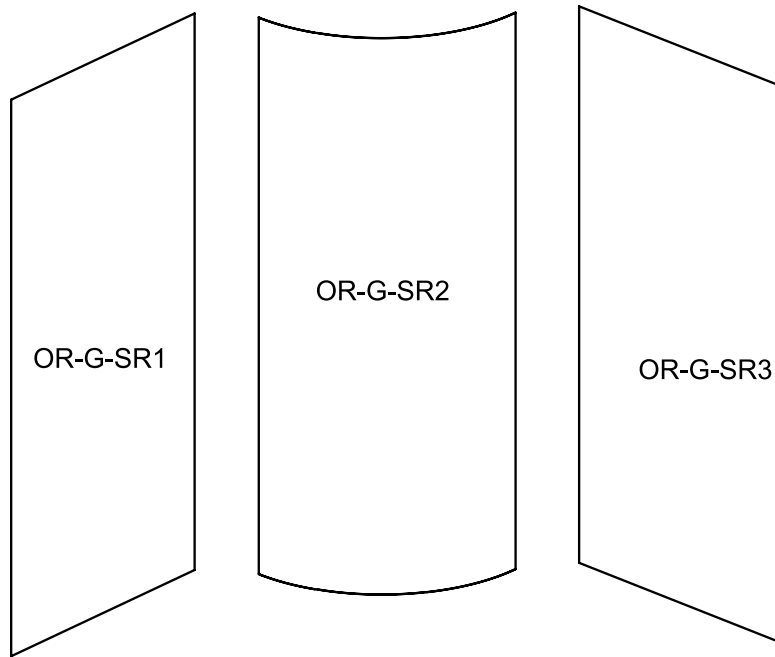

Acceptable File formats:

Illustrator CS6 or below
Photoshop CS6 or below
Art time will be charged if files need to be fixed or altered to meet guidelines. When sending files please be sure to include all support art (fonts, linked images, etc.)

Font Specifications:

Fonts must be converted to outlines.

Bleeds:

All orbital truss graphics require specific bleeds. The sizes listed above represent the finished graphic size. Please keep all logos, type and critical information at least 1" in from each edge of the finished graphic.

Dye Sublimation: 2" bleed around the perimeter.

Color:

All files are printed as CMYK format. All critical Pantone colors need to be called out in the file or specified on the order as Coated or Uncoated swatches.

Resolution:

All raster files (either print files or linked files) must be at 100-120 pixels per inch at 100%

Finishing Details:

When graphics are notched, a 7/8" square is cut in the appropriate location.

FS: Graphics mounted to front of truss system

BS: Graphics mounted to back of truss system

Dye Sublimation graphics are attached to truss with velcro.

To ensure quality, please note:

Each graphic has a specific code or number located on the graphic. The electronic print files provided must be named accordingly. Using this coding system will allow us to preflight and prepare your files for print more efficiently. **If you fail to provide your graphic files in this format, additional charges may be necessary to complete your printed materials.**

SIRIUS FLOOR PLAN:

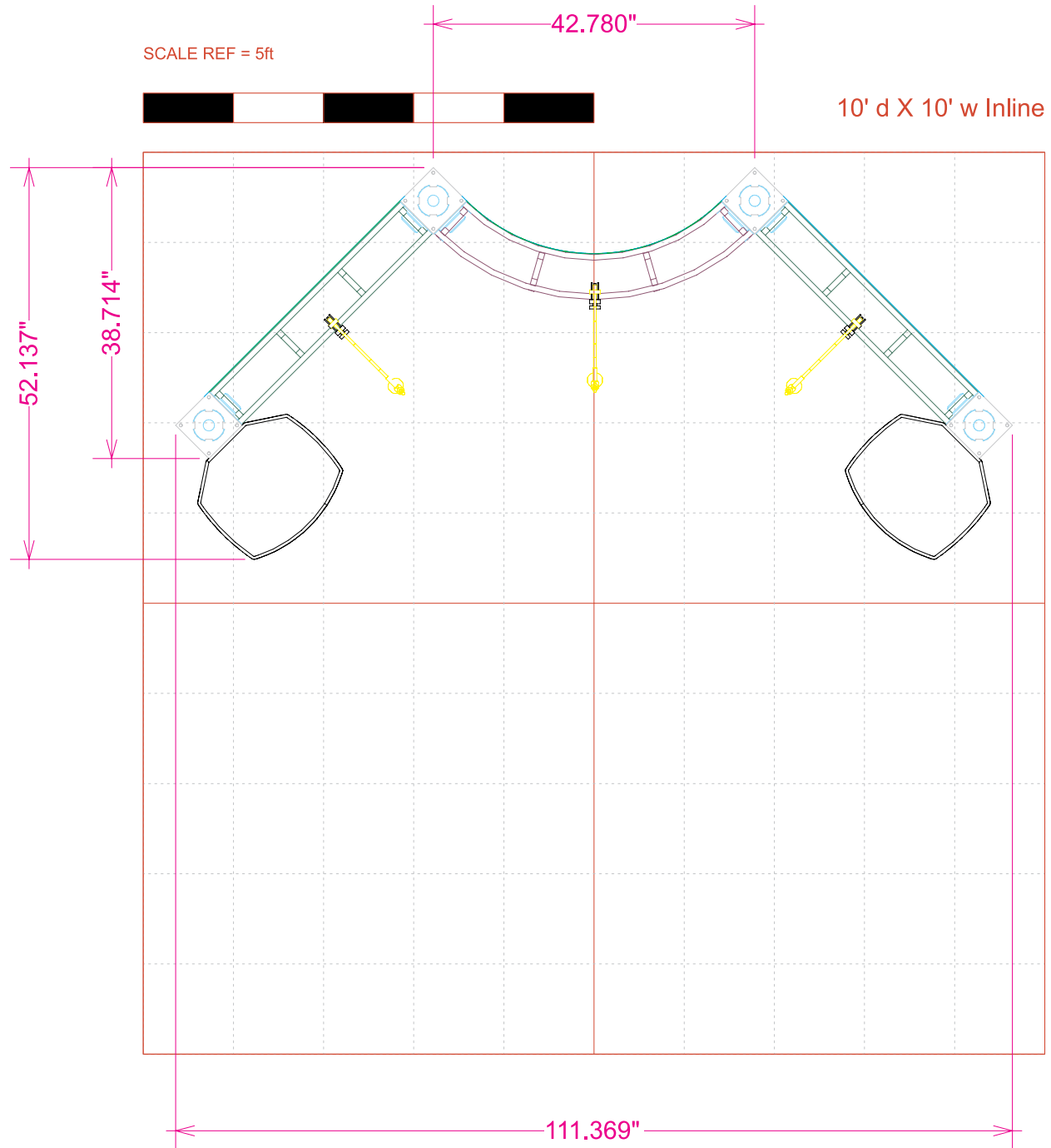

SIRIUS COLOR CODED PARTS:

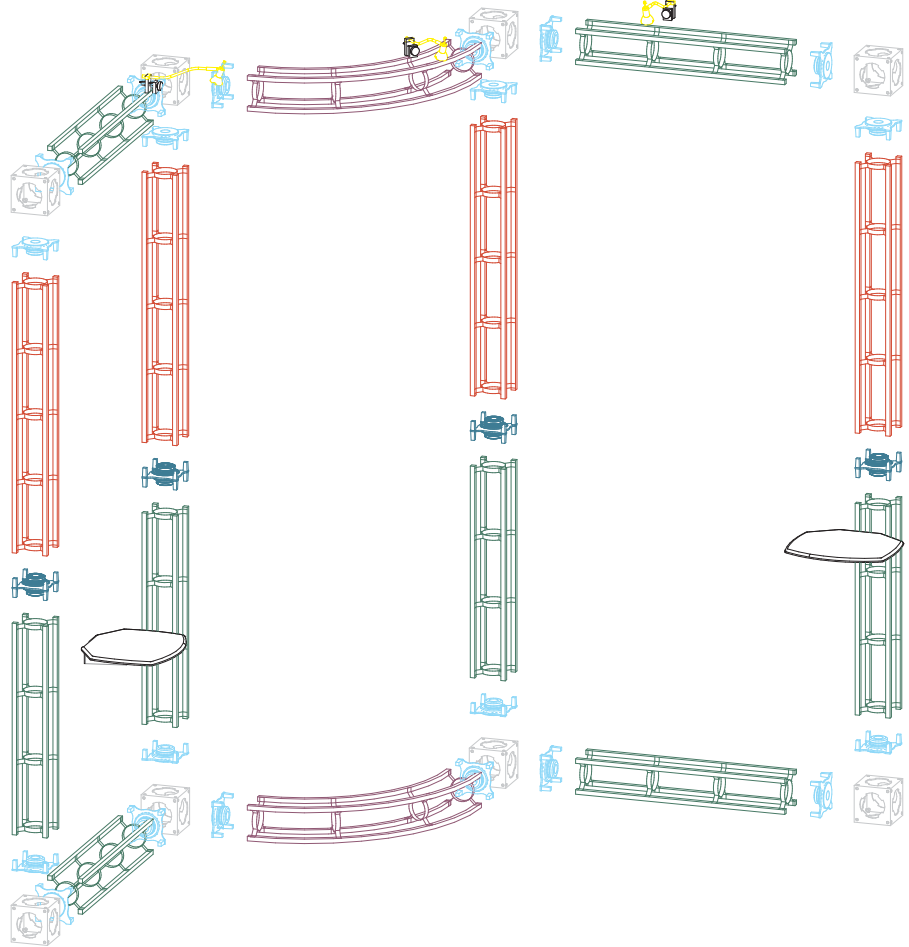

Parts exploded

