

# Poster Stand with Shelves: Assembly Instructions

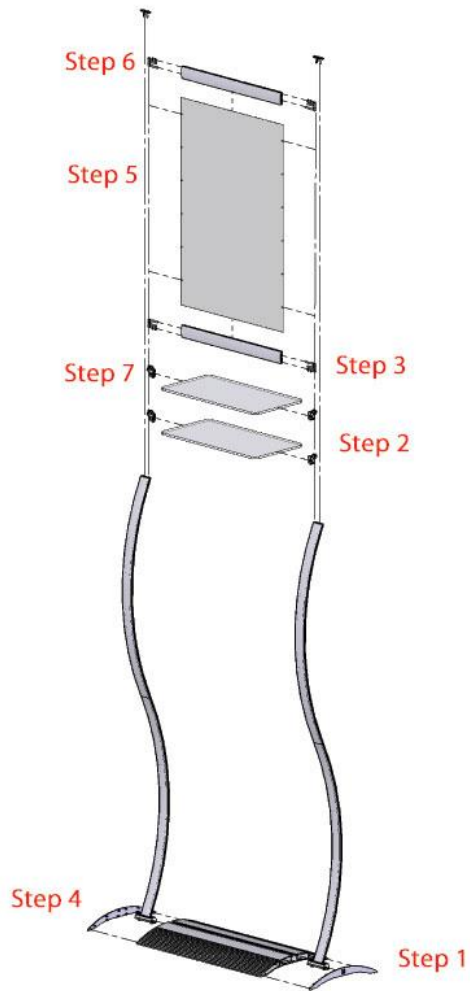

## **You will need:**

- Phillip's head screwdriver
- Flat head screwdriver
- Water level
- Measuring tape
- \*All hardware is included

## **Assembly Tips:**

- When tightening side extrusions to base, remember to keep the extrusion flush to the groove of the base. The extrusion tends to "rock" in the base groove, which if tightened this way, your display will not be perpendicular.
- When measuring space for your poster and shelves, please remember to include the poster bars in your estimations.
- The plastic lenses feature "bump-outs" to help guide your lenses down the grooves of the side extrusions.
- If you are having difficulty inserting the shelves, loosen one of the side extrusions, and slide it slightly out the base to grant you more room.
- Once you've attached your shelves, use a water leveler to ensure your shelves are level.

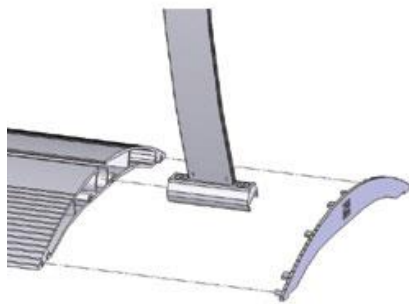

**1.** Remove end cap from base. Slide (1) side support into base and secure it in place with a screwdriver. Replace end cap.



**2.** Measure the desired height for each shelf. (Please remember to leave enough room for your poster.) Attach and secure each shelf bracket onto both side supports, using a Phillips Head screwdriver and the provided Allen key.

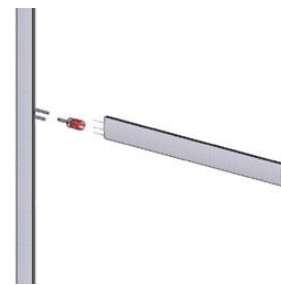

**3.** Measure and attach lower poster connectors to both extrusions. Slide the bar onto the connector.

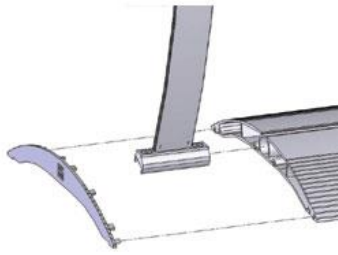

**4.** Slide the second side support into the base and secure it in place with a screwdriver. (Please remember to connect the poster bar as well.) Replace end cap.

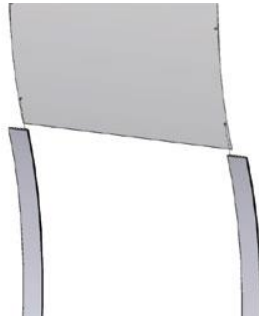

**5.** Insert poster and lenses (at the same time) into the grooved channels. Make sure the bottom portion of the poster slides into the bottom bar.

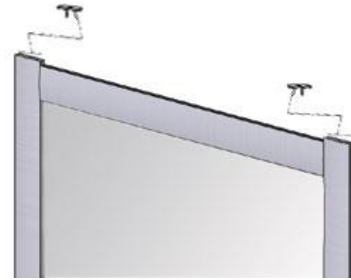

**6.** Connect second poster bar to the top of your display. Insert end caps.

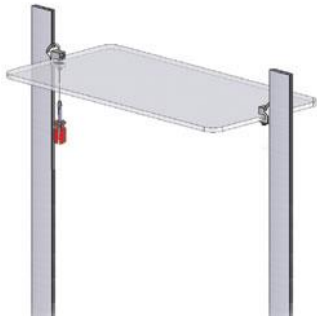

**7.** Insert each shelf and secure in place by tightening each plastic set screw with a Flat Head screwdriver.



Your shelving unit is now set up and ready for accessories!