

SWR199PBK

Pocket Spinner Assembly Instructions

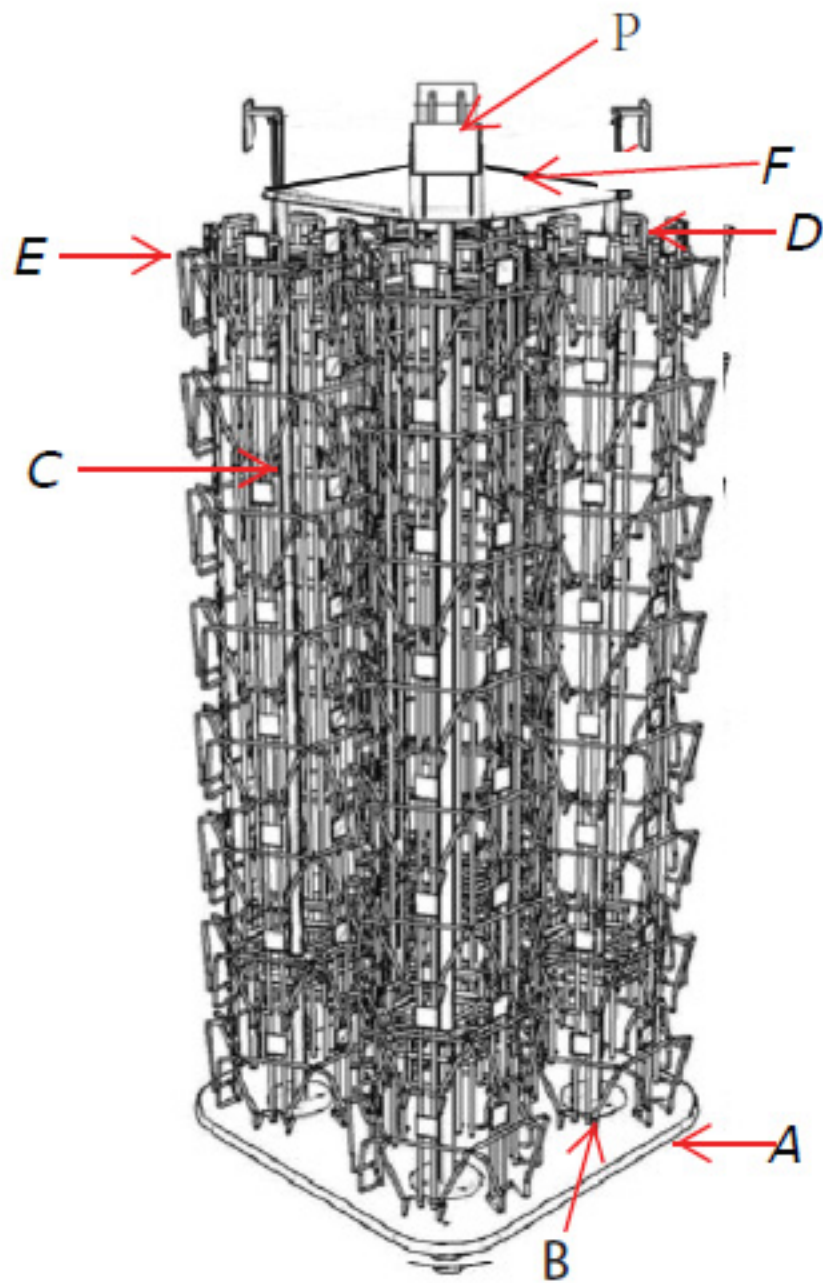

Parts Identification

Item	Qty	Description
A	1	Base
B	4	Lower Pole
C	4	Upper Pole
D	8	Hub
E	24	8 Pocket Strip
F	1	Header Plate
H	1	Hardware Bag
P	4	Sign holder

Hardware bag includes the following part (H)



H1 12x



H2 1x

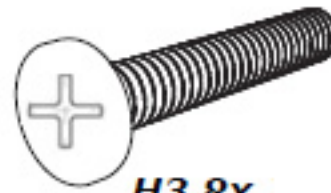

H3 8x



H4 8x

Step 1: Mount each Lower Pole (B) to the Base (A) passing a total of (3) Machine Screws (H1) through the holes in the bottom plate of each pole and into the Base. Machine Screw (H3) through the holes in the Base.

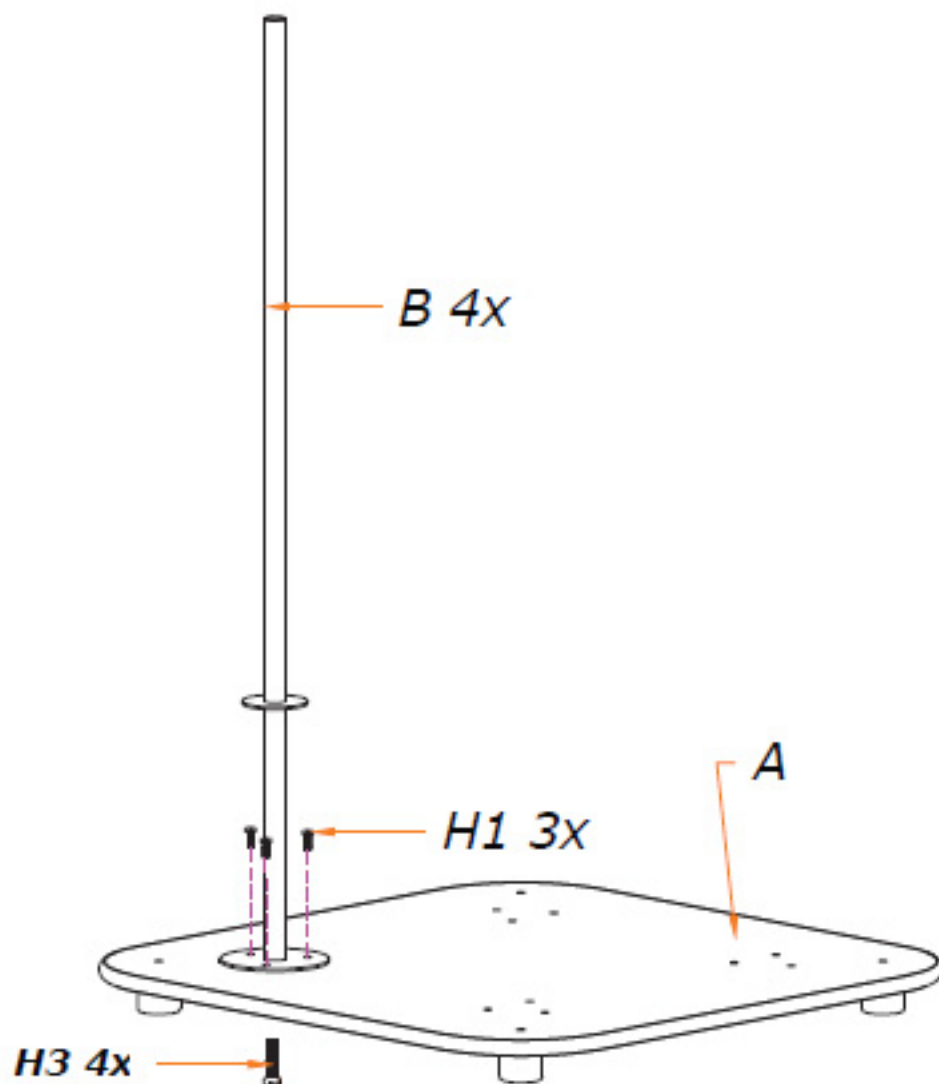

Step 2: Slide a Bearing (H4) and a Hub (D) over each Lower Pole (B)

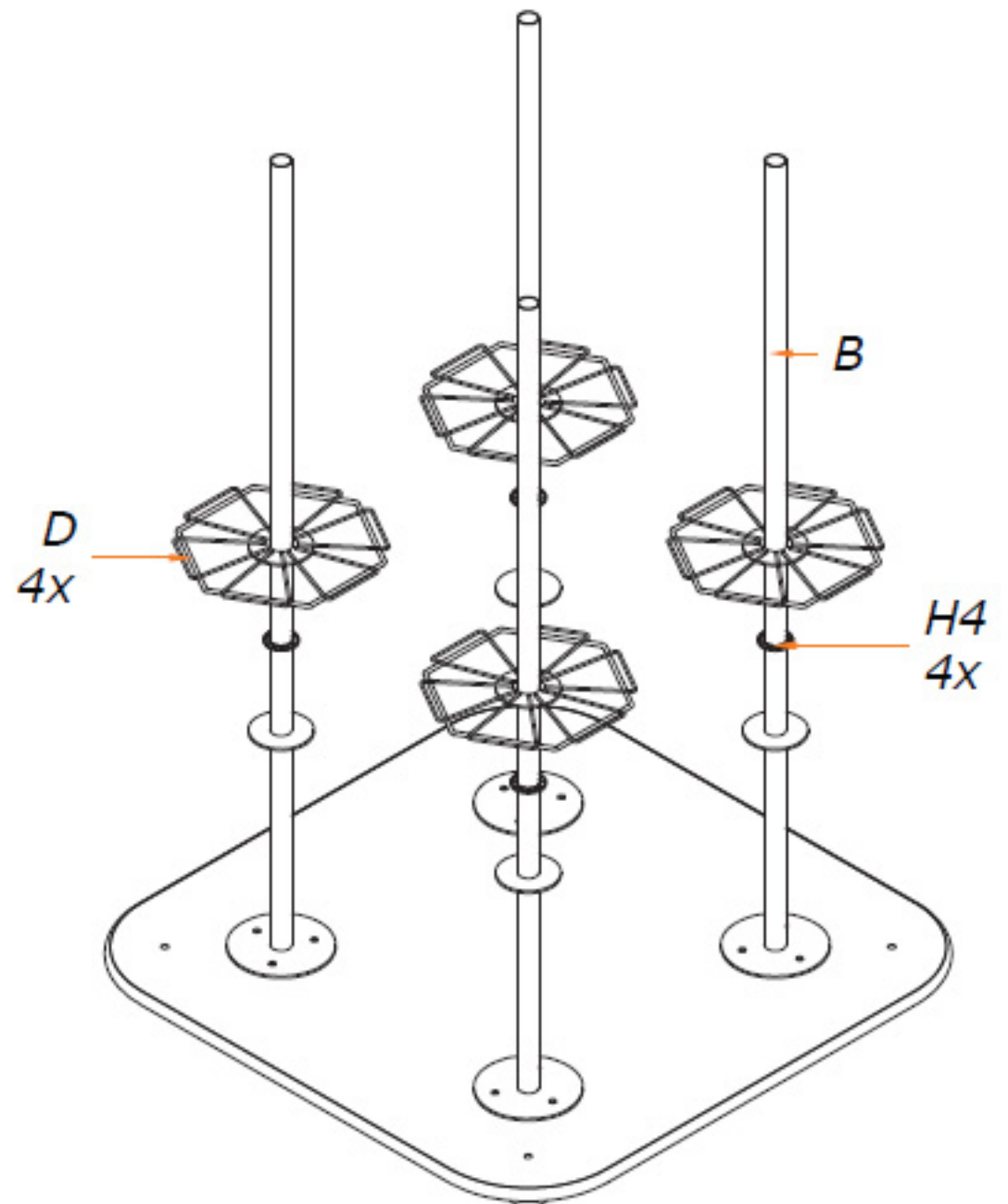

Step 3: Slide an Upper Pole (C) into each Lower Pole (B).

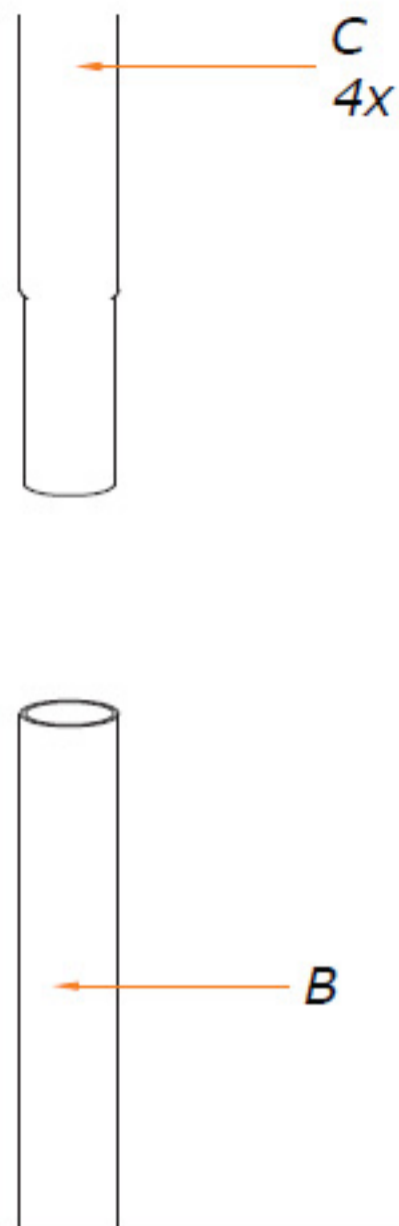

Step 4: Slide a Hub (D) over each Upper Pole (C).

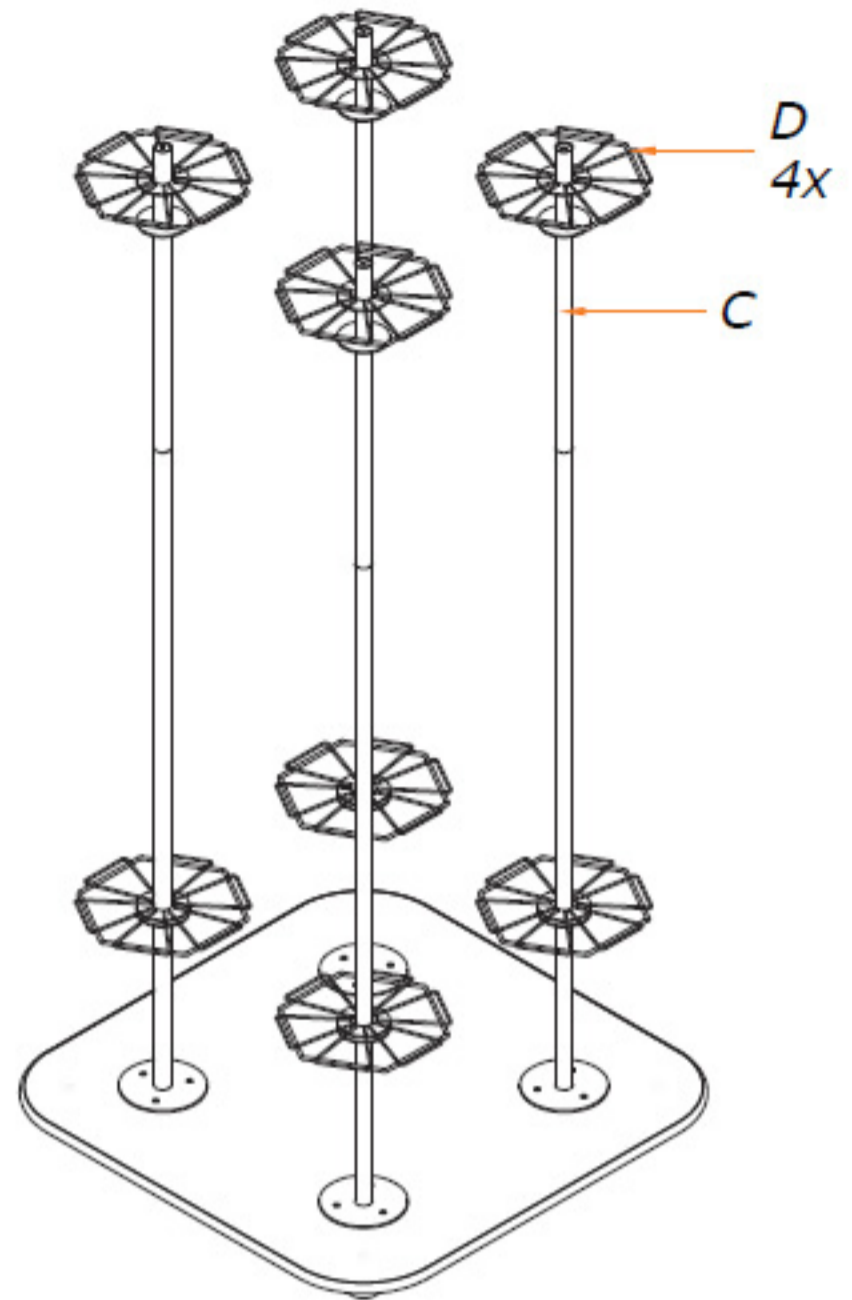

Step 5: Hook a total of (6) 8 Pocket Strips (E) over each pair of Hubs (D).

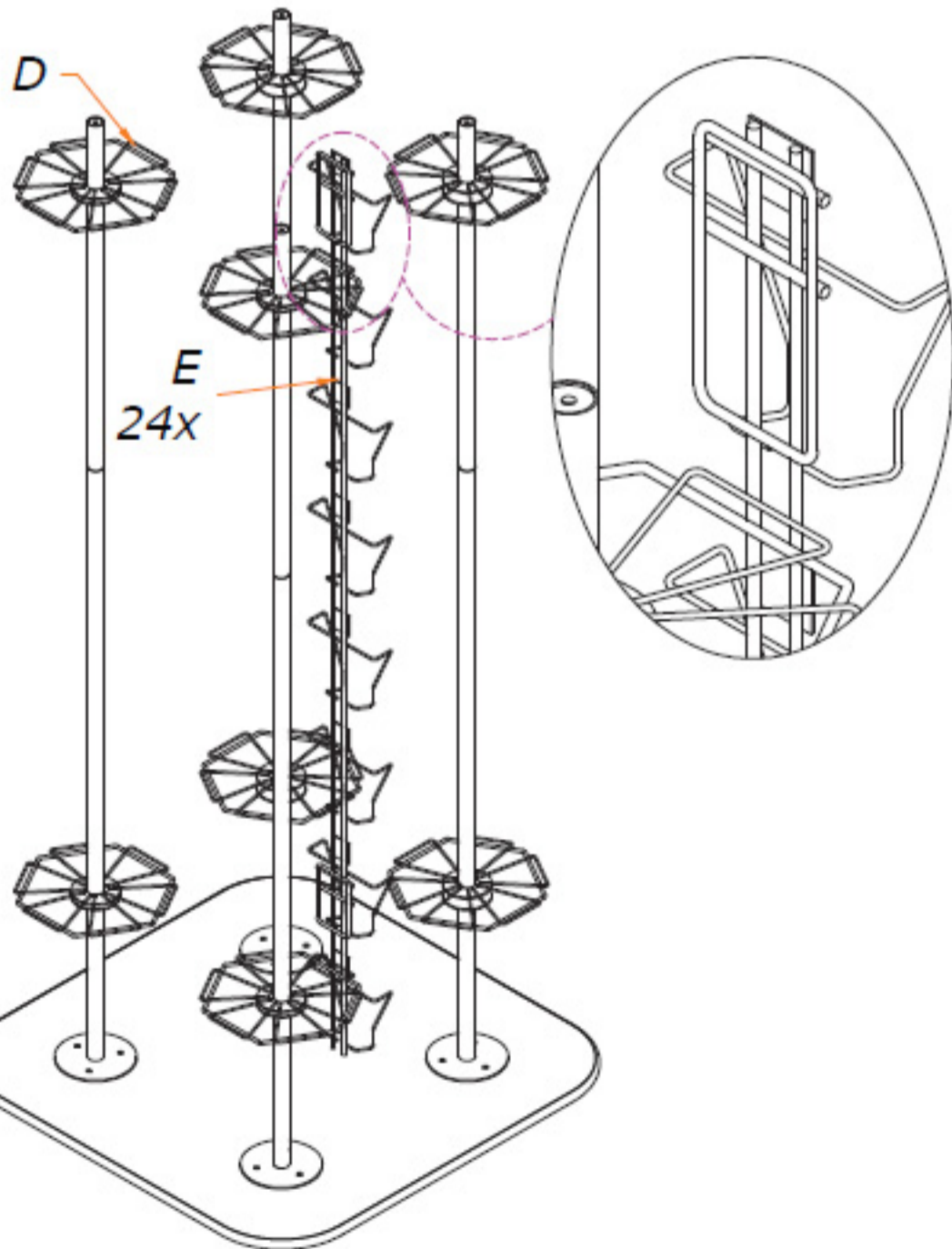

Step 6: Secure the Header Plate (F) to the top of each Pole Set. Pass a Machine Screw (H3) thru each thru hole in the Header Plate and into the top of each Pole Set.

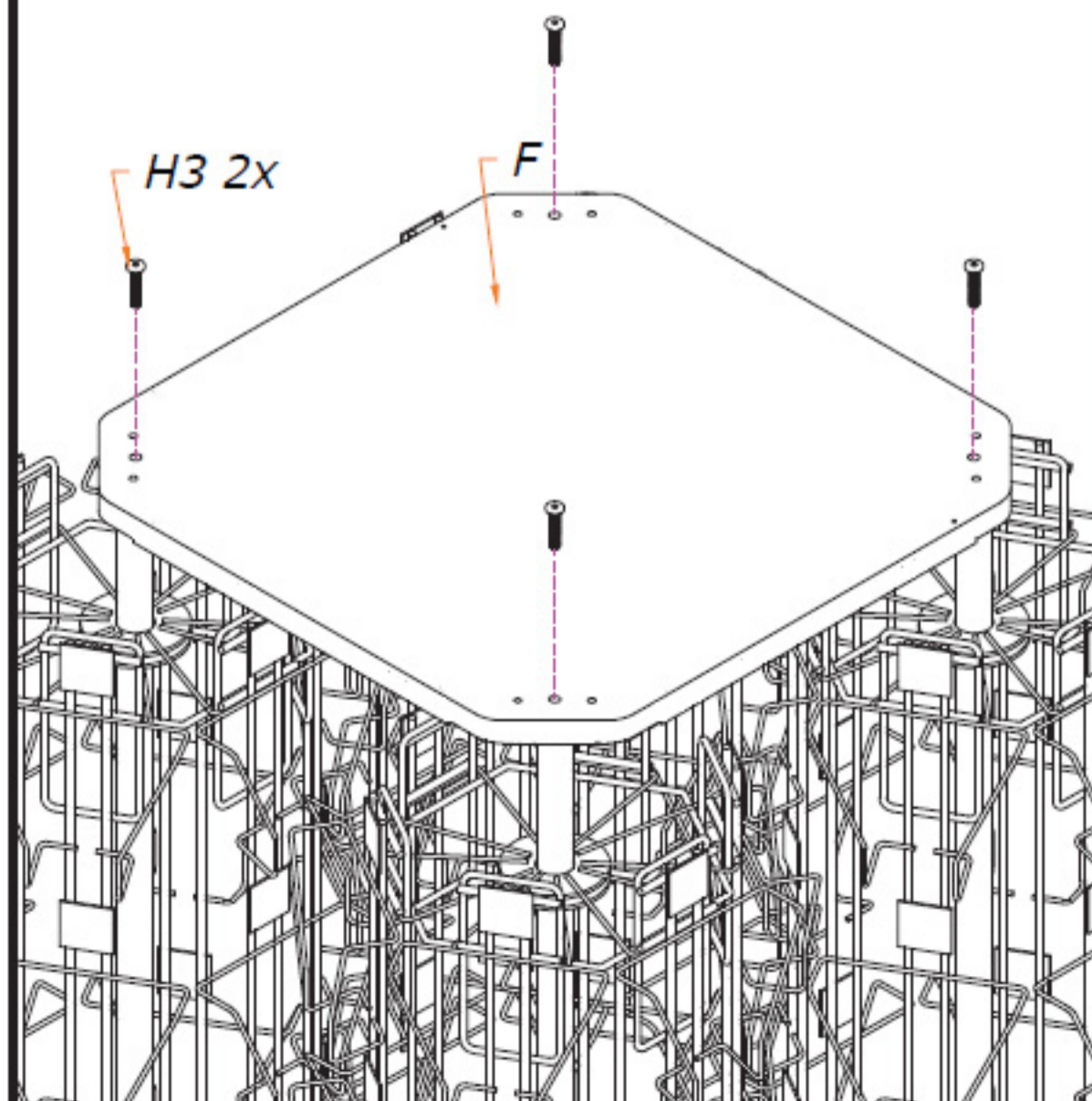

Step 7: Insert a Sign holder (P) into each corresponding set of pre-drilled holes in the Header Plate (F).

