

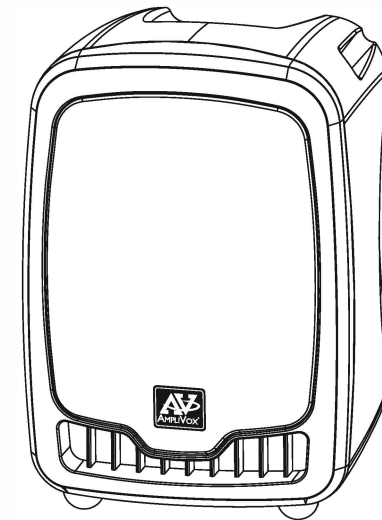

WWW.AMPLI.COM

PAMPLAY

Wireless Portable Sound System with Media Player
User manual



CLAIMS UNDER THE WARRANTY

To obtain Warranty Service, contact AmpliVox (800-267-5486) to be assigned a Return Authorization number (RA#). After receiving a RA#, the defective unit is to be returned to AmpliVox in either its original packaging or packaging affording an equal degree of protection. You will bear the cost of shipping the product to AmpliVox. If the product is covered by the warranty, AmpliVox will bear the cost of shipping product back to you after the completion of service under this warranty.

Return shipping will be charged to you for products not covered by the warranty or requiring no warranty repair.

The following information must be presented to obtain Warranty Service: (a) the RA# must be clearly and legibly marked on the outside of shipping carton, (b) proof of purchase, which clearly indicates the name and address of the seller, the date of purchase and the product type, which is evidence that this product is within the Warranty Period. Please further include (c) your return address, (d) daytime telephone number, and (e) reason for return.

LIMITATION OF WARRANTY

This warranty is only valid for the original purchaser and will automatically terminate prior to expiration if this product is sold or otherwise transferred to another party. The warranty provided by AmpliVox in this statement applies only to products purchased for use, and not for resale. It does not apply to open box purchases, which are sold "as is" and without any warranty. Specifically exempt from warranty are limited-life consumable components subject to normal wear and tear, such as microphone windscreens, ear cushions, modular plugs, ear tips, decorative finishes, batteries, and other accessories. This warranty is invalid if the factory-applied serial number, date code label, or product label has been altered or removed from this product. This Warranty does not cover cosmetic damage or damage due to misuse, abuse, negligence, Acts of Nature, accident, disassembling or modification of, or to any part of, the product. This Warranty does not cover damage due to improper operation, maintenance or installation, or attempted repair by anyone other than AmpliVox. Any unauthorized repairs will void this warranty.

REPAIRS OR REPLACEMENTS AS PROVIDED UNDER THIS WARRANTY ARE THE EXCLUSIVE REMEDY OF THE CONSUMER. AMPLIVOX SHALL NOT BE LIABLE FOR ANY INCIDENTAL OR CONSEQUENTIAL DAMAGES FOR BREACH OF ANY EXPRESS OR IMPLIED WARRANTY ON THIS PRODUCT. EXCEPT TO THE EXTENT PROHIBITED BY LAW, THIS WARRANTY IS EXCLUSIVE AND IN LIEU OF ALL OTHER EXPRESS AND IMPLIED WARRANTIES WHATSOEVER, INCLUDING BUT NOT LIMITED TO THE WARRANTY OF MERCHANTABILITY AND FITNESS FOR A PRACTICAL PURPOSE.

NOTE! This warranty gives you specific legal rights. You may have other rights which vary from location to location. Some jurisdictions do not allow the exclusion or limitation of incidental or consequential damages or implied warranties, so the above exclusions may not apply to you. This warranty does not affect your legal (statutory) rights under your applicable national or local laws.

CONTROL PANEL

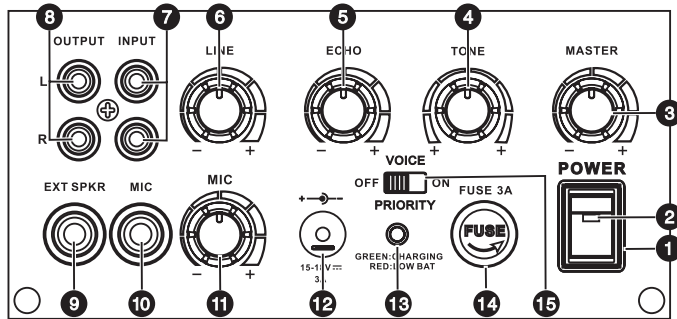

- ① **Power Switch**
- ② **Power Indicator Light:** Lights up when power is turned on.
- ③ **Master Volume Control**
- ④ **Tone Control:** Adjust Bass and Treble
- ⑤ **Echo Control:** Add more or less delay effect
- ⑥ **RCA Jacks Volume Control:** Control volume of input jack
- ⑦ **RCA Input Jacks:** Plug in audio source with RCA cable
- ⑧ **RCA Output Jacks:** Connect to audio recording source
- ⑨ **External Speaker Jack:** For cable with 1/4" male connector
- ⑩ **Wired Microphone Jack:** Plug in wired microphone with 1/4" male connector
- ⑪ **Microphone Volume Control:** Control wired microphone output
- ⑫ **DC Input Jack:** Plug one end of AC adapter cord into jack and the other end into AC outlet.
- ⑬ **Charging / Low Battery Indicator:** Flashing Green when charging, turns red when battery is low and needs to be charge. **CHARGE IMMEDIATELY!**
- ⑭ **Fuse Holder**
- ⑮ **Voice Priority Function Switch:** Facilitates announcements and paging by automatically reducing the volume of all the other inputs when switch to "ON" position

IMPORTANT SAFETY INSTRUCTIONS

Before using this product, read the instruction manual for important safety information. Please retain this manual for future reference and warranty information.

Troubleshooting & Servicing

Do not attempt to service or repair the device yourself. Refer all servicing to qualified service personnel. Do not attempt to modify the device in anyway. Doing so could invalidate your warranty.

Moisture and heat sources

Do not use this apparatus near water (for example, sinks, baths, pools) or expose it to rain, moisture, dripping or splashing liquids. Do not expose the unit to high temperatures, high humidity or direct sunlight.

Cleaning

When cleaning the device, please use a soft, dry cloth. Never use benzene, paint-thinner, or other chemicals on the device.

Location

Place the device in stable location, so it will not fall causing damage to the device or bodily harm.

Intended use

The product may only be used with the original parts intended for it. The product may only be used in closed and dry rooms. The intended use includes adherence to the specified installation instructions. The manufacturer accepts no liability for damage arising due to improper use.

WARNING:

Changes or modifications to this unit not expressly approved by the party responsible for compliance could void the user's authority to operate the equipment.

IMPORTANT

This device complies with Part 15 of the FCC Rules. Operation is subject to the following two conditions:

(1) This device may not cause harmful interference, and (2) this device must accept any interference received, including interference that may cause undesired operation.

The unit's circuitry may cause interference to nearby radios. To prevent interference, either switch the unit off or move away from the affected radio.

NOTE: This equipment complies within the limits for a class B digital device, pursuant to Part 15 of the FCC Rules. These limits are designed to provide reasonable protection against harmful interference in a residential installation. This equipment generates, uses and can radiate radio frequency energy and, if not installed and used in accordance with the instructions, may cause harmful interference to radio communications. However, there is no guarantee that interference will not occur in a particular installation. If this equipment does cause harmful interference to radio or television reception, which can be determined by turning the equipment off and on, the user is encouraged to try to correct the interference by one or more of the following measures:

- Increase the separation between the equipment and receiver.
- Connect the equipment into an outlet on a circuit different from that to which the receiver is connected.

• Consult the dealer or an experienced radio / TV technician for help.

NOTE: Shielded cables may be required to be used with this unit to ensure compliance with the Class B FCC limits.

BATTERIES

1. Hold the body of microphone in hand and twist off bottom section of microphone.
2. Insert two "AA" batteries.
3. Twist bottom section back on to microphone.

BATTERY STATUS

The life expectancy of the two batteries is about 10 hours.

When the "BATTERY" symbol on the display screen keeps flashing the batteries should be replaced immediately.

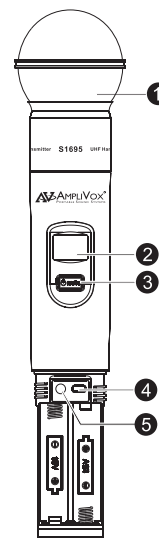

Functions

① Interchangeable Microphone Head

② LCD Screen

③ Power / Mute Control Switch

④ Select Button

⑤ Microphone Input Sensitivity Ad-

justment—is used to set the gain of microphone. If you are a soft talking speaker you will need to turn the control counter clockwise. Turn clockwise if you are a loud talker. Use plastic screwdriver that is supplied.

• **TURN ON MICROPHONE:** Push and hold the "POWER/MUTE" ③ button until LCD screen lights up.

• **TO MUTE:** Press "POWER/MUTE" button twice to MUTE. Channel number will flash when muted. Press button again twice to remove "MUTE".

• **TURN OFF MICROPHONE:** Push and hold the "POWER/MUTE" ③ button for 2 seconds to turn microphone "OFF".

• **SELECT CHANNEL (Manual):** Press and hold the "SELECT" ④ button for 2 seconds until you only see the word Channel and channel number.

• To change channel, when flashing, press the "SELECT" ④ button until you reach the desired channel. Flashing will stop after 10 seconds and channel is now set.

• **LOCK / UNLOCK CHANNEL:** Push the "POWER/MUTE" ③ button and "SELECT" button ④ at the same time to lock or unlock channel.

When locked, channel cannot be changed. "LOCKED" symbol appears in upper left-hand corner.

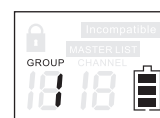

WIRELESS RECEIVER

- ① IR WINDOW—Sends IR signal to the microphone transmitter to synchronize channel.
- ② Power / Volume Switch
- ③ ASC: Push button to start auto synchronization.
- ④ Mute Level Adjustment
- ⑤ AF: Audio Frequency Indicator
- ⑥ RF: Radio Frequency Incicator
- ⑦⑧ Manual Channel UP / Down
- ⑨ Channel Display

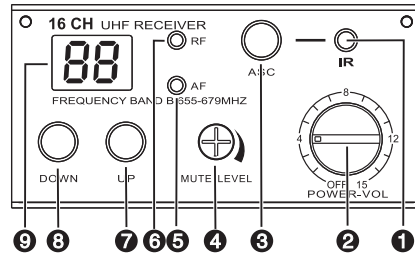

RECEIVER SET-UP

The receiver has its own **POWER / VOLUME** Control ②. Turn Power On. A Frequency Channel will appear in the Channel Display ⑨ Press Select Buttons ⑦⑧ to select a channel. Channel number must match channel number on wireless microphone transmitter.

MUTE LEVEL ④ is set at half way mark when it leaves the factory. If speaker sound is breaking up, turn level clockwise with small screwdriver until condition improves.

WIRELESS HANDHELD MICROPHONE

Screw off the lower bottom section of microphone and insert 2 - "AA" 1.5 Volt alkaline batteries.

IMPORTANT: Because the microphone has an **AUTO SYNC** function, you first select channel you wish to use on the receiver. Then press the ASC button ③ the IR light will start to flash. Turn on microphone and point end of microphone at the flashing IR light on receiver and the microphone will auto sync to the same channel as selected on the receiver.

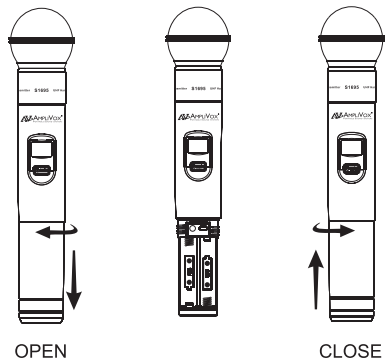

Thank you for choosing the **SW725 Wireless PA System** from *AmpliVox Portable Sound Systems*.

We are excited in introducing this truly unique system. Our system combines flexibility with functionality. Please refer to this user guide as you enjoy the unique capabilities of another quality product from *AmpliVox Portable Sound Systems*.

We encourage you to visit our website www.ampli.com to register your product for its warranty coverage, sign up to receive our newsletter, download our catalog, and learn more about the complete line of *AmpliVox* audio visual products, including portable PA systems, and lecterns.

FEATURES

1. This portable amplifier is suitable for outdoor (not waterproof) and indoor audio including vocal and music playing.
2. High-quality, user replaceable rechargeable battery, which is convenient for both indoor and outdoor use.
3. Multiple input/output jacks can connect to nearly any audio device and broadcast for any moderate sized gathering.
4. Place on virtually any surface or use with tripod with built-in 5/8" dia. pole mount.
5. With 1 wired microphone input jack and up to 2 wireless microphones (optional 2nd wireless microphone not included) it can be used by multiple people simultaneously.
6. Rugged plastic enclosure.
7. USB / SD CARD / RECORDER / BLUETOOTH

Setup and Installation

AC Operation

1. Turn Master Volume control to minimum setting.
2. Insert the DC plug, at the end of the AC adapter cord into the DC input jack.
3. Plug the AC adapter into the AC power outlet.
4. Turn on the power switch.

Battery Operation

1. To enable battery operation, first ensure that the internal battery is fully charged. To do this, follow the instructions below for AC Operation and let the battery charge for at least 12 hours.

PACKAGE CONTENTS

SW725 Wireless Portable PA
 Wireless Handheld Microphone
 Wired Hand held Microphone
 Protective Cover with Pockets
 3.5mm Male to Stereo RCA Male Cable
 AC/DC Adapter with Power Cord
 Remote Control

Back panel function

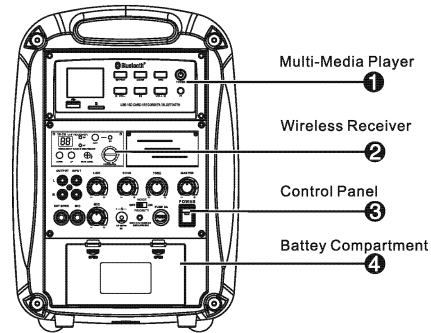

RECHARGEABLE BATTERY

Typically the battery gives 3-4 hours of continuous operation after fully charged.

Charging Instructions:

1. Charge the battery for 12 hours before using.
2. Plug the external AC/DC power supply into outlet.
3. The CHARGING indicator will flash green. When the battery is full charged the indicator will be a steady green.
4. There is an automatic charging shut off. The charging circuit inside the battery will turn off by itself once the battery is charged.
 This special overcharge protection control circuit will extend the battery life.
5. Charge the battery at least once a month.
6. When the LOW BATT light turns RED the battery should be charged immediately.
7. Remove the battery when not on use for extended periods (up to 10 days)

Maintenance Tips:

1. Charge the battery for 12 hours after use.
2. Charge the battery at least once a month
3. Battery specification is 12v/2.6AH. It can be recharged over 300 times if used correctly.
4. Using a different AC/DC adapter other than the one supplied may cause damage to the battery.

Notes:

- a. A low battery may caused distortion or unwanted noise. The battery should be charged immediately after use.
- b. Turn the power switch to OFF position after use.

Media Player / Remote Control Functions

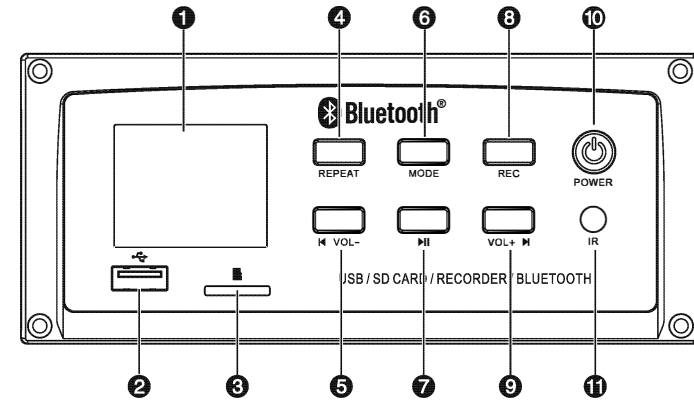

- ① **Information Screen**
- ② **USB Socket:** For Thumb drive memory device containing MP3 music files.
- ③ **SD Card Socket:** For SD memory card device containing MP3 music files.
- ④ **Repeat Button:** Repeats song currently playing. Press button again to cancel.
- ⑤ **Previous / Volume Decrease:** Press button to back up to previous song/folder when using USB/SD devices. Press to decrease volume of media player. This is in addition to the main volume control function.
- ⑥ **Mode Button:** Select between USB /SD / Bluetooth / FM Radio functions. For Bluetooth select symbol. Pairing will automatically start. On you Bluetooth device select **AMPLI VOX 725**.
- ⑦ **Play / Pause Button:** Start playback of current selection, and also stops the selection when pressed during playback. When pressed again, playback resumes at the point where the selection was stopped.
- ⑧ **Record Button:** Press to start recording to USB thumb drive or SD card using microphones.
- ⑨ **Forward / Volume Increase:** Press button to move to the next song / folder when using USB/SD devices. Press to increase volume of media player. This is in addition to the main volume control function.
- ⑩ **Power Button:** Press to turn on Media Player.
- ⑪ **IR Port:** Used for receiving signal from remote control.
- ⑫ **Play Rec:** Play previous recorded.
- ⑬ **FM Search:** Search for FM channels. (Not available)
- ⑭ **Number Buttons**

Remote Control
 Only controls media player functions

